

The Accu-Coder™ Model 725- A Step Above The Rest

All Size 2.5" Encoders Are Not Created Equal!

Size 2.5" encoders (2.5" diameter) are among the most popular encoders in the world. As a result, nearly every encoder manufacturer in the world makes them. The problem is, not every Size 2.5" encoder is built to the same exacting standards of quality and reliability as the Model 725 Accu-Coder™ from Encoder Products Company (EPC).

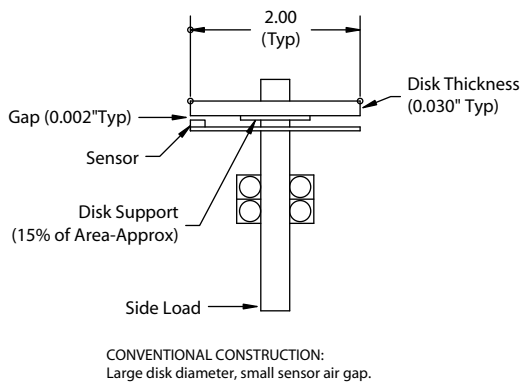

Typical Construction Of A Size 2.5" Encoder

So, what's the problem?

If you have used other Size 2.5" encoders, you have probably experienced reliability problems such as sensor crashes and disk breakage. The typical construction of a Size 2.5" encoder (shown at left) uses a single set of closely spaced shaft bearings and a large diameter (typically 2.0") glass disk mounted to the shaft. The glass disk is generally supported on the shaft hub by just 15% of the surface area and has a thickness of 0.030". In addition, these units commonly require a relatively narrow air gap (typically 0.002") between the disk and sensor in order to properly calibrate the signal. Because of this combination, a small amount of side loading (force from installation requirements, vibration, shock, or other conditions) to move the shaft enough for the attached disk to make contact with the sensor or some other portion of the stationary PCB. The result is damage to the disk or sensor, or even disk breakage.



Then, what's the solution?

When design engineers at EPC set out to design a better Size 2.5" encoder, their goal was to solve the typical problems without affecting the price of the encoder. The result - the Model 725N, a Size 2.5" encoder worthy of the Accu-Coder™ name. The first goal was to make it more difficult for shaft movement from side load to cause damage. Using EPC's advanced sensor technology, the air gap between the disk and sensor doubled from 0.002" to 0.004", and the disk diameter was reduced from 2.0" to 1.3". The next goal was to increase the durability of the disk itself. Disk thickness was more than doubled (from 0.030" to 0.062"), manufactured using EPC's proprietary process, and supported by 30% of the disk surface area. Finally, it was time to improve the resistance to side load movement altogether, so the 725N was given dual heavy-duty bearings, generously spaced to disperse the load over a larger portion of the shaft.

But EPC's innovative engineering team wasn't satisfied. They really wanted to solve the problems of a truly rough environment. What they designed was the Model 725I - The industrial 725 housing option, an encoder that is as robust as possible within its price category. Using the improvements developed in the 725N, EPC's engineering team developed the "encoder-within-an-encoder" design. With this design, the 725I adds two extra, heavy-duty bearings to the two contained within the internal encoder for a total of four bearings! These two extra bearing sets are separated in such a way that side load stresses become isolated between the two bearing sets and never reach the inner encoder. In addition, the internal encoder is mounted to the 725I's housing using EPC's pioneering flex mount, further isolating the internal optics and electronics from outside forces.

The ACCU-CODER™ Advantage

The Accu-Coder™ Model 725- A Step Above The Rest



Which Model 725 Accu-Coder™ Is Right For You? Decide For Yourself!

Better - The Model 725N

In the Model 725N, EPC has designed out the common problems experienced by the average Size 2.5" encoder. Notice the generous air gap (double that of typical Size 2.5" encoders), thick code disk (more than twice the thickness), small diameter, large disk support area, and large bearing spacing - each an element which increases durability and reliability.

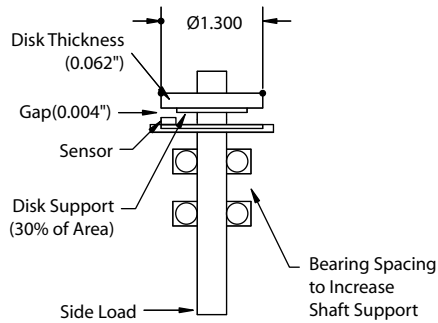

Best - The Model 725I

The Model 725I takes the design improvements made in the Model 725N, places them in their own internal encoder housing, and surrounds the internal unit with a second, rugged housing with a separate set of heavy duty bearings. This results in the most rugged Size 2.5" encoder available.

