

Model 755A NEMA

Incremental Thru-Bore & Motor Mount Encoders



Features

- Standard NEMA Mounting
- Up to 30,000 Cycles Per Revolution
- High Temperature Option

The Model 755A NEMA Mount Accu-Coder™ with its integral shaft coupling, mounts directly onto NEMA motors. It is designed for easy installation on industrial size 23 or 34 motor frames. It features standard bolt circle patterns, and can accommodate shaft sizes of 0.250", 0.375", or 6 mm. With its rugged all metal housing, and a wide range of CPR options, it will fit in many different applications, providing years of trouble free use.

Common Applications

Robotics, Assembly Machines, Motor-Mounted Feedback, Phototypesetters, Printers & Digital Plotters, Elevator Controls, Medical Diagnostic Equipment

Model 755A NEMA Ordering Guide

Blue type indicates price adder options. Not all configuration combinations may be available. Contact Customer Service for details.

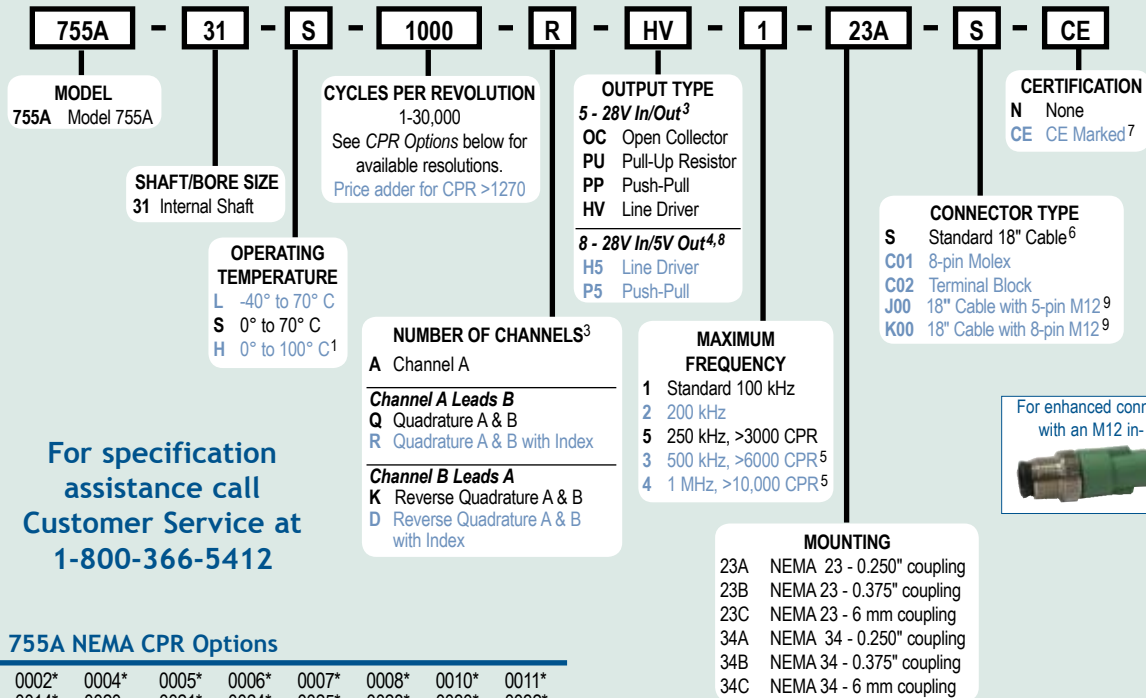

For specification assistance call Customer Service at 1-800-366-5412

Model 755A NEMA CPR Options

0001*	0002*	0004*	0005*	0006*	0007*	0008*	0010*	0011*
0012*	0014*	0020	0021*	0024*	0025*	0028*	0030*	0032*
0033*	0034*	0035*	0038*	0040*	0042*	0045*	0050*	0060
0064*	0100	0120	0125	0128*	0144*	0150*	0160*	0192*
0200	0240*	0250	0254*	0256*	0300	0333*	0360	0400
0500	0512	0600	0625*	0635	0665*	0720	0768*	0800
0889	0900*	1000	1024	1200	1201 ^a	1203 ^a	1204 ^a	1250 ^a
1270 ^a	1440	1500	1800	2000	2048	2400 ^a	2500	2540 ^a
2880 ^a	3000 ^a	3600 ^a	4000 ^a	4096 ^a	5000 ^a	6000 ^a	7200 ^a	7500 ^a
9000 ^a	10,000 ^a	10,240 ^a	12,000 ^a	12,500 ^a	14,400 ^a	15,000 ^a	18,000 ^a	20,000 ^a
20,480 ^a	25,000 ^a	30,000 ^a						

* Contact Customer Service for High Temperature Option.

^a High Temperature Option (H) limited to 85° C maximum for these CPR options.

New CPR values are periodically added to those listed. Contact Customer Service to determine all currently available CPR values. Special disk resolutions are available upon request. A one-time NRE fee may apply.

Model 755A NEMA

Model 755A NEMA Specifications

Electrical

Input Voltage.....4.75 to 28 VDC max for temperatures up to 70° C
 4.75 to 24 VDC for temperatures between 70° C to 100° C
 Input Current.....100 mA max with no output load
 Input Ripple.....100 mV peak-to-peak at 0-100 kHz
 Output FormatIncremental- Two square waves in quadrature with channel A leading B for clockwise shaft rotation, as viewed from the encoder mounting face. See *Waveform Diagrams* below.
 Output Types.....Open Collector- 100 mA max per channel
 Pull-Up- 100 mA max per channel
 Push-Pull- 20 mA max per channel
 Line Driver- 20 mA max per channel (Meets RS 422 at 5 VDC supply)
 Index.....Occurs once per revolution. The index for units >3000 CPR is 90° gated to Outputs A and B. See *Waveform Diagrams* below.

Max Frequency.....Up to 1 MHz.
 Noise Immunity.....Tested to BS EN61000-4-2; IEC801-3; BS EN61000-4-4; DDENV 50141; DDENV 50204; BS EN55022 (with European compliance option); BS EN61000-6-2; BS EN50081-2
 Symmetry.....1 to 6000 CPR: 180° (±18°) electrical at 100 kHz output
 6001 to 20,480 CPR: 180° (±36°) electrical
 Quad Phasing.....1 to 6000 CPR: 90° (±22.5°) electrical at 100 kHz output
 6001 to 20,480 CPR: 90° (±36°) electrical
 Min Edge Sep.....1 to 6000 CPR: 67.5° electrical at 100 kHz output
 6001 to 20,480 CPR: 54° electrical
 >20,480 CPR: 50° electrical
 Rise Time.....Less than 1 microsecond
 Accuracy.....Instrument and Quadrature Error : For 200 to 1999 CPR, 0.017° mechanical (1.0 arc minutes) from one cycle to any other cycle.
 For 2000 to 3000 CPR, 0.01° mechanical (0.6 arc minutes) from one cycle to any other cycle. Interpolation error (units > 3000 CPR only) within 0.005° mechanical. (Total Optical Encoder Error = Instrument + Quadrature + Interpolation)

Mechanical

Max Shaft Speed.....7500 RPM. Higher shaft speeds may be achievable, contact Customer Service.
 Coupling Bore.....0.250", 0.375", or 6 mm
 Starting Torque.....0.14 oz-in typical
 4.0 oz-in typical for -40° C operation
 Moment of Inertia..... 2.8×10^{-4} oz-in-sec²
 Max Acceleration..... 1×10^5 rad/sec²
 Electrical Conn.....18" cable (foil and braid shield, 24 AWG conductors), 5- or 8-pin M12 (12 mm) in-line
 connector with 18" cable (braid shield), 8-pin Molex, Terminal Block
 Housing.....Black non-corrosive finish
 Bearings.....Precision ABEC ball bearings
 Mounting.....NEMA 23 and 34
 Weight.....4.50 oz typical on NEMA 23
 6.75 oz typical on NEMA 34

Environmental

Operating Temp.....0° to 70° C for standard models
 -40° to 70° C for low temperature option
 0° to 100° C for high temperature option
 (0° to 85° C for certain resolutions, see CPR Options.)
 Storage Temp.....-25° to +85° C
 Humidity.....98% RH non-condensing
 Vibration.....10 g @ 58 to 500 Hz
 Shock.....50 g @ 11 ms duration

Model 755A Size 23 NEMA Mount (23A, 23B, 23C)

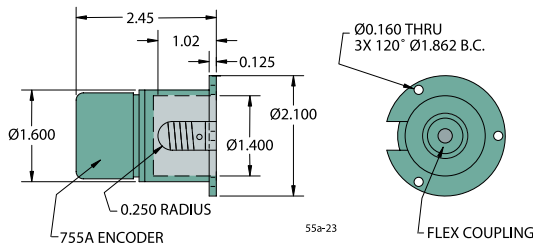

Model 755A Size 34 NEMA Mount (34A, 34B, 34C)

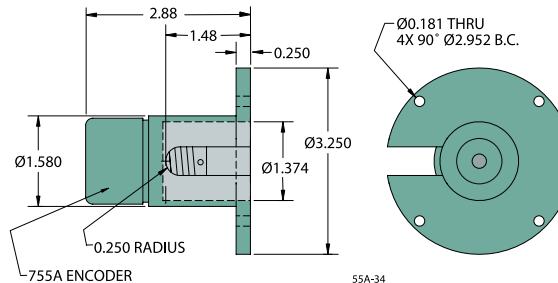

All dimensions are in inches with a tolerance of ±0.005" or ±0.01" unless otherwise specified

Waveform Diagrams

Line Driver and Push-Pull

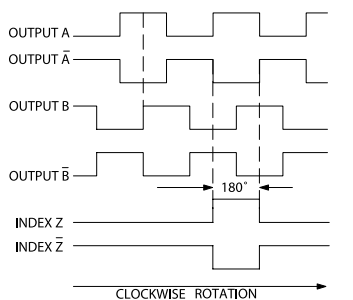

Open Collector and Pull-Up

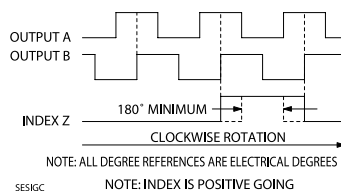

Wiring Table

Function	Cable Wire Color	Terminal Block	8-pin Molex	5-pin M12 ²	8-pin M12 ²
Com	Black	7	2	3	7
+VDC	White	8	1	1	2
A	Brown	1	8	4	1
A'	Yellow	2	7	-----	3
B	Red	3	4	2	4
B'	Green	4	3	-----	5
Z	Orange	6	6	5	6
Z'	Blue	5	5	-----	8
Shield	Bare ¹	-----	-----	-----	-----

¹CE Option: Cable shield (bare wire) is connected to internal case
²CE Option: Read Technical Bulletin TB111

Incremental Thru-Bore & Motor Mount Encoders