

# Model 770

Incremental Thru-Bore & Motor Mount Encoders



## Features

- Slim Profile - Only 1.00" Deep
- Fits NEMA Size 56C Thru 184C Motor Faces (4.5" AK)
- Incorporates Opto-ASIC Technology
- Resolutions to 4096 CPR

The Model 770 C-face encoder is a rugged, high resolution encoder designed to mount directly on NEMA C-face motors. Both sides of the encoder are C-face mounts, allowing additional C-face devices to be mounted to this encoder. Unlike many C-face kit type encoders, the Model 770 contains precision bearings and an internal flex mount, virtually eliminating encoder failures and inaccuracies induced by motor shaft runout or axial end-play. The advanced Opto-ASIC design provides advanced noise immunity necessary for many industrial applications. This encoder is ideal for applications using induction motors and flux vector control. The Model 770 provides speed and position information for drive feedback in a slim profile - only 1.00" thick. The Thru-Bore design allows fast and simple mounting of the encoder directly to the accessory shaft or to the drive shaft of the motor, using the standard motor face (NEMA sizes 56C - 184C). The tough, all metal housing resists the vibration and hazards of an industrial environment.

## Common Applications

Motor Feedback, Velocity & Position Control, Conveyors, Variable Speed Drives, Mixing & Blending Motors, Assembly & Specialty Machines

## Model 770 Ordering Guide

Blue type indicates price adder options. Not all configuration combinations may be available. Contact Customer Service for details.

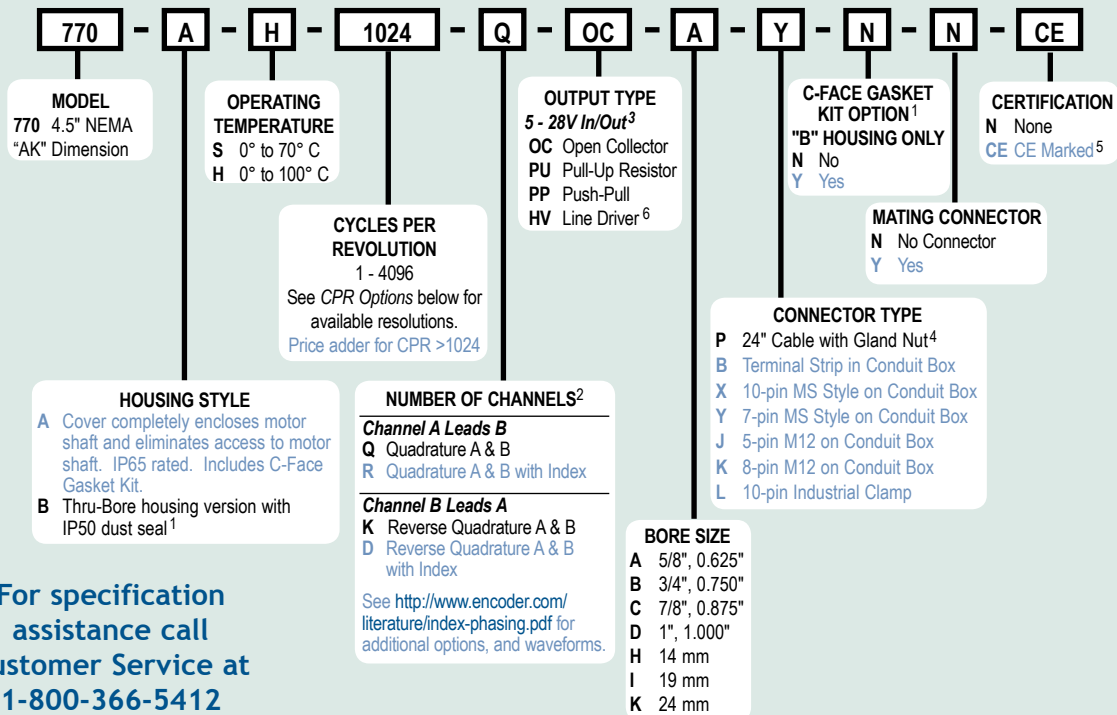

For specification assistance call Customer Service at 1-800-366-5412

### Model 770 CPR Options

0060	0100	0120	0240	0250	0256
0500	0512	0600	1000	1024	2048
2500	4096				

Contact Customer Service for other disk resolutions; not all disk resolutions available with all output types

### NOTES:

- 1 Thru-Bore version may be IP65 sealed if mounted between two C-face devices with optional gasket kit. Select 'Yes' under C-face Gasket Kit Option.
- 2 Contact Customer Service for index gating options.
- 3 5 to 24 VDC max for high temperature option.
- 4 For non-standard cable lengths, add a forward slash (/) plus cable length expressed in feet. Example: P/6 = 6 feet of cable.
- 5 Please refer to **Technical Bulletin TB100: When to Choose the CE Option** at [www.encoder.com](http://www.encoder.com).
- 6 Not available with 5-pin M12 connector. Available with 7-pin MS connector only without Index Z.

# Model 770

## Model 770 Specifications

### Electrical

Input Voltage.....4.75 to 28 VDC max for temperatures up to 70° C  
 4.75 to 24 VDC for temperatures between 70° C to 100° C  
 Input Current.....100 mA max with no output load  
 Input Ripple.....100 mV peak-to-peak at 0 to 100 kHz  
 Output Format.....Incremental- Two square waves in quadrature with channel A leading B for clockwise shaft rotation, as viewed from the mounting face. See *Waveform Diagrams* below.  
 Output Types.....Open Collector- 100 mA max per channel  
 Pull-Up- 100 mA max per channel  
 Push-Pull- 20 mA max per channel  
 Line Driver- 20 mA max per channel (Meets RS 422 at 5 VDC supply)  
 Index.....Once per revolution.  
 0475 to 4096 CPR: Gated to output A  
 0001 to 0474 CPR: Ungated  
 See *Waveform Diagrams* below.

Max Frequency.....200 kHz  
 Noise Immunity.....Tested to BS EN61000-4-2; IEC801-3; BS EN61000-4-4; DDENV 50141; DDENV 50204; BS EN55022 (with European compliance option); BS EN61000-6-2; BS EN50081-2  
 Symmetry.....180°(±18°) electrical  
 Quad. Phasing.....90°(±22.5°) electrical  
 Min. Edge Sep.....67.5° electrical  
 Rise Time.....Less than 1 microsecond

### Mechanical

Max Shaft Speed.....6000 RPM. Higher shaft speeds may be achievable, contact Customer Service.  
 Bore Size.....0.625", 0.750", 0.875", 1.000", 14 mm, 19 mm, and 24 mm  
 Bore Tolerance.....+0.0015"/-0.000"  
 User Shaft Tolerances  
 Radial Runout.....0.005"  
 Axial Endplay.....±0.050"  
 Moment of Inertia.....3.3 x 10<sup>-3</sup> oz-in-sec<sup>2</sup> typical  
 Electrical Conn.....Gland nut with 24" cable (foil and braid shield, 24 AWG conductors), Terminal Strip in conduit box, 7- or 10-pin MS Style, 5- or 8-pin M12 (12 mm), 10-pin Industrial Clamp  
 Housing.....All metal construction  
 Mounting.....NEMA 56C to 184C  
 Weight.....2.60 lb with gland nut  
 3.00 lb with all other connector options  
 Note: All weights typical

### Environmental

Operating Temp.....0° to 70° C for standard models  
 0° to 100° C for high temperature option  
 Storage Temp.....-25° to 100° C  
 Humidity.....98% RH non-condensing  
 Vibration.....10 g @ 58 to 500 Hz  
 Shock.....50 g @ 11 ms duration  
 Sealing.....IP65 for Option A housing style with gasket kit  
 IP50 for Option B housing style

## Model 770 With Gland Nut (P)

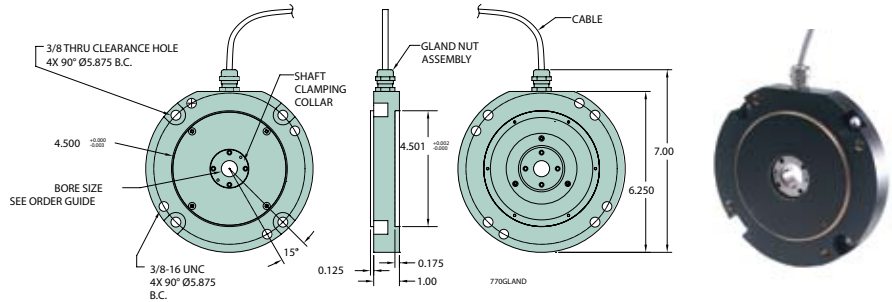

## Model 770 With Conduit Box (B, X, Y, J, K)

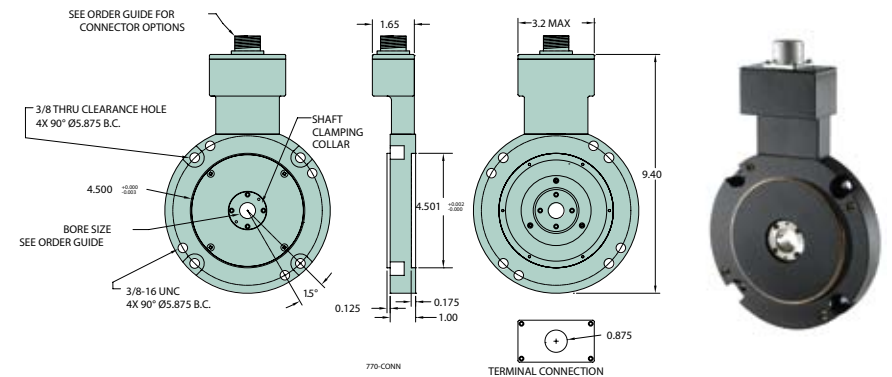

### Optional Housing Style (A) Protective Cover

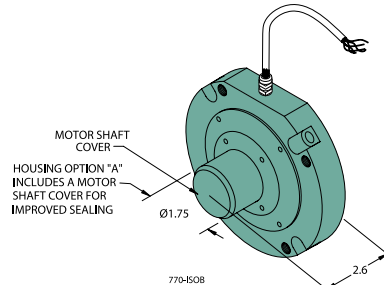

All dimensions are in inches with a tolerance of ±0.005" or ±0.01" unless otherwise specified

CONNECTOR TYPE	HEIGHT
6- or 7-PIN MS	0.67"
10-PIN MS	0.90"
5- or 8-PIN M12	0.50"

### Waveform Diagrams

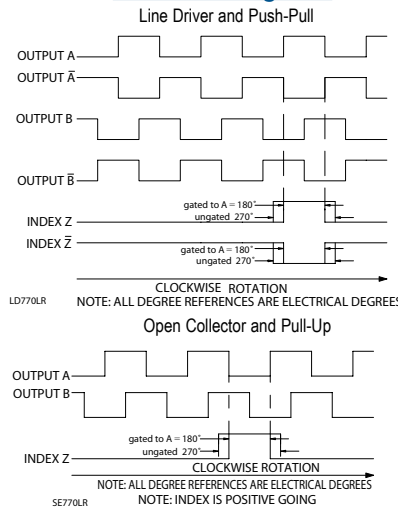

### Wiring Table

Function	Gland Cable Wire Color	5-pin M12 <sup>1</sup> PU, PP, OC	8-pin M12 <sup>2</sup>	10-pin MS	7-pin MS HV	7-pin MS PU, PP, OC	Term. Block	10-pin Indust. Clamp
Com	Black	3	7	F	F	F	2	1
+VDC	Red	1	2	D	D	D	1	6
A	White	4	1	A	A	A	3	3
A'	Brown	---	3	H	C	---	4	8
B	Blue	2	4	B	B	B	5	2
B'	Violet	---	5	I	E	---	6	7
Z	Orange	5	6	C	---	C	7	4
Z'	Yellow	---	8	J	---	---	8	9
Shield	Bare <sup>1</sup>	---	---	---	---	---	---	---
Case	---	---	---	G <sup>2</sup>	G <sup>2</sup>	G <sup>2</sup>	9 <sup>3</sup>	10 <sup>3</sup>

<sup>1</sup>CE Option: Cable shield (bare wire) is connected to internal Case  
<sup>2</sup>CE Option: Pin G is connected to Case  
 Non CE Option: Pin G has No Connection  
<sup>3</sup>CE Option: Pin 10 is connected to Case  
 Non CE Option: Pin has No Connection  
<sup>4</sup>CE Option: Read Technical Bulletin "TB111" at [www.encoder.com](http://www.encoder.com)

Incremental Thru-Bore & Motor Mount Encoders