

# Model 776

Incremental Thru-Bore & Motor Mount Encoders



### Features

- Slim Profile - Only 1.36" In Depth
- Thru-Bore Design For Easy Mounting
- Incorporates Opto-ASIC Technology
- Resolutions to 4096
- Bore Options to 1.875"
- CE Marking Available

The Thru-Bore Series Accu-Coder™ Model 776 encoder is designed to fit directly on either a motor or other shaft where position, direction, or velocity information is needed. The advanced Opto-ASIC based electronics provide the superior noise immunity necessary in many industrial applications. The Model 776 conveniently features a clamp type mount for fast and easy mounting over a large range of shaft sizes. An optional anti-rotation flex mount maintains housing stability.

### Common Applications

Motor Feedback, Velocity & Position Control, Robotics, Conveyors, Material Handling

### Model 776 Ordering Guide

Blue type indicates price adder options. Not all configuration combinations may be available. Contact Customer Service for details.

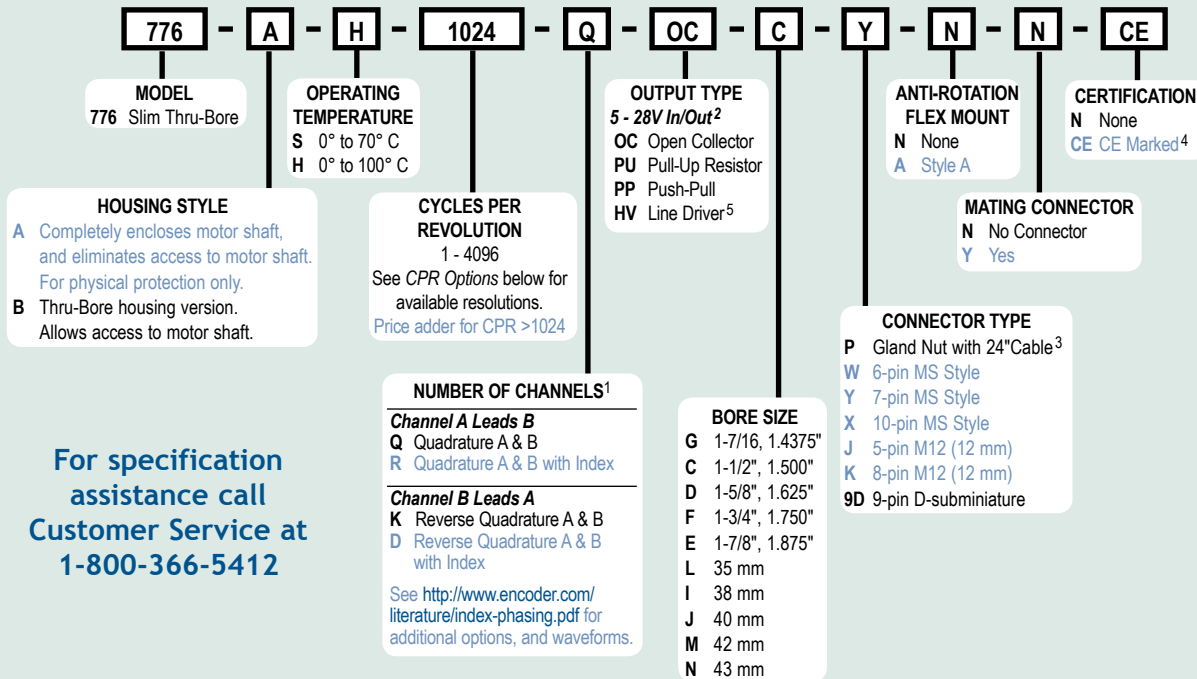

For specification assistance call Customer Service at 1-800-366-5412

### Model 776 CPR Options

0060	0100	0120	0240	0250	0256
0500	0512	0600	1000	1024	2048
2500	4096				

Contact Customer Service for other disk resolutions; not all disk resolutions available with all output types

### NOTES:

- 1 Contact Customer Service for index gating options.
- 2 5 to 24 VDC max for high temperature option.
- 3 For non-standard cable lengths, add a forward slash (/) plus cable length expressed in feet. Example: P/6 = 6 feet of cable.
- 4 Please refer to Technical Bulletin TB100: **When to Choose the CE Option** at [www.encoder.com](http://www.encoder.com).
- 5 Not available with 5-pin M12 or 6-pin MS connector. Available with 7-pin MS connector only without Index Z.

# Model 776

## Model 776 Specifications

### Electrical

- Input Voltage.....4.75 to 28 VDC max for temperatures up to 70° C  
4.75 to 24 VDC for temperatures between 70° C to 100° C
- Input Current.....100 mA max with no output load
- Input Ripple.....100 mV peak-to-peak at 0 to 100 kHz
- Output Format.....Incremental- Two square waves in quadrature with channel A leading B for clockwise shaft rotation, as viewed from the mounting face. See *Waveform Diagrams* below.
- Output Types.....Open Collector- 100 mA max per channel  
Pull-Up- 100 mA max per channel  
Push-Pull- 20 mA max per channel  
Line Driver- 20 mA max per channel (Meets RS 422 at 5 VDC supply)
- Index.....Once per revolution.  
0475 to 4096 CPR: Gated to output A  
0001 to 0474 CPR: Ungated  
See *Waveform Diagrams* below.
- Max Frequency.....200 kHz
- Noise Immunity.....Tested to BS EN61000-4-2; IEC801-3; BS EN61000-4-4; DENV 50141; DENV 50204; BS EN55022 (with European compliance option); BS EN61000-6-2; BS EN50081-2
- Symmetry.....180° (±18°) electrical
- Quad. Phasing.....90° (±22.5°) electrical
- Min. Edge Sep.....67.5° electrical
- Rise Time.....Less than 1 microsecond

### Mechanical

- Max Shaft Speed.....3500 RPM. Higher shaft speeds may be achievable, contact Customer Service.
- Bore Size.....1.500", 1.625", 1.750", 1.875", 35 mm, 38 mm, 40 mm, 42 mm, 43 mm
- User Shaft Tolerances  
Radial Runout.....0.005"  
Axial Endplay.....±0.030" with appropriate flex mount
- Moment of Inertia.....3.3 x 10<sup>-3</sup> oz-in-sec<sup>2</sup> typical
- Electrical Conn.....Gland nut with 24" cable (foil and braid shield, 24 AWG conductors), 6-, 7-, or 10-pin MS Style, 5- or 8-pin M12 (12 mm), or 9-pin D-sub- miniature
- Housing.....All metal construction
- Mounting.....Thru bore with single-screw clamp mount
- Weight.....1.0 lb with gland nut or D-sub connector option 1.5 lb with MS connector option  
Note: All weights typical

### Environmental

- Operating Temp.....0° to 70° C for standard models  
0° to 100° C for high temperature option
- Storage Temp.....-25° to 100° C
- Humidity.....98% RH non-condensing
- Vibration.....10 g @ 58 to 500 Hz
- Shock.....50 g @ 11 ms duration
- Sealing.....IP50

## Model 776 With Gland Nut Cable (P)

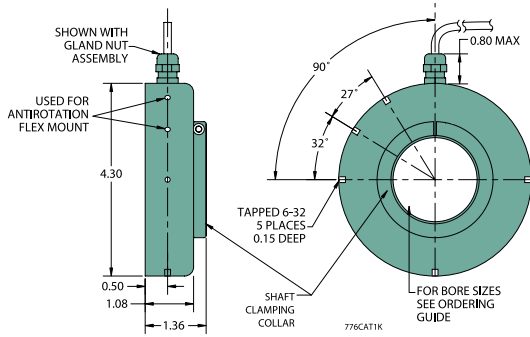

## Model 776 With 9-Pin D-Sub Connector (9D)

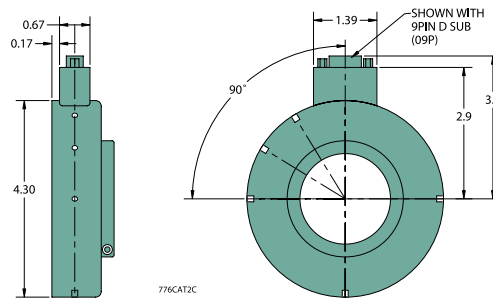

## Model 776 Extended Housing (W, X, Y, J, K)

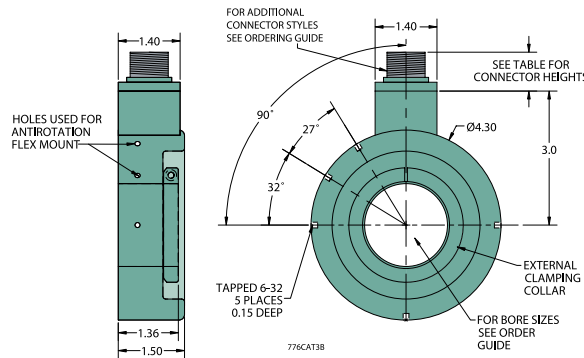

CONNECTOR TYPE	HEIGHT
6- or 7-PIN MS	0.67"
10-PIN MS	0.90"
5- or 8-PIN M12	0.50"



All dimensions are in inches with a tolerance of ±0.005" or ±0.01" unless otherwise specified

### Waveform Diagrams

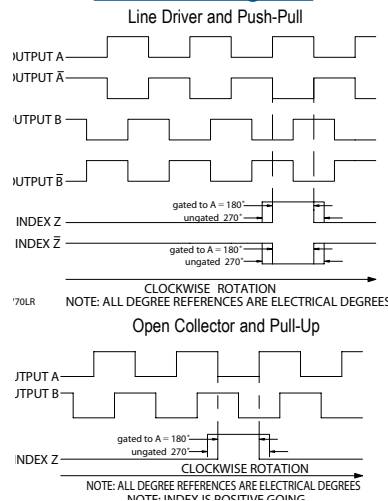

### Wiring Table

Function	Gland Cable Wire Color	5-pin M12 <sup>1</sup> PU, PP, OC	8-pin M12 <sup>2</sup>	10-pin MS	7-pin MS HV	7-pin MS PU, PP, OC	6-pin MS PU, PP, OC	9-pin D-sub
Com	Black	3	7	F	F	F	A, F	9
+VDC	Red	1	2	D	D	D	B	1
A	White	4	1	A	A	A	D	2
A'	Brown	---	3	H	C	---	---	3
B	Blue	2	4	B	B	B	E	4
B'	Violet	---	5	I	E	---	---	5
Z	Orange	5	6	C	---	C	C	6
Z'	Yellow	---	8	J	---	---	---	7
Shield	Bare <sup>1</sup>	---	---	---	---	---	---	---
Case	---	---	---	G <sup>2</sup>	G <sup>2</sup>	G <sup>2</sup>	---	8 <sup>3</sup>

<sup>1</sup>CE Option: Cable shield (bare wire) is connected to internal Case  
<sup>2</sup>CE Option: Pin G is connected to Case  
 Non CE Option: Pin G has No Connection  
<sup>3</sup>CE Option: Pin 8 is connected to Case  
 Non CE Option: Pin 8 has No Connection  
<sup>4</sup>CE Option: Read Technical Bulletin "TB111" at www.encoder.com

Incremental Thru-Bore & Motor Mount Encoders