

Model 865T



Features

- A C-Face Thru-Bore Encoder With Stainless Steel Housing
- Fits NEMA Size 56C Thru 184 C Motor Faces (4.5" AK)
- Slim Profile - Only 1.00" Deep
- Incorporates Opto-ASIC Technology
- Resolutions to 4096 CPR

The Model 865T C-face encoder is a rugged, high resolution encoder designed to mount directly on NEMA C-face motors. Both sides of the encoder are C-face mounts, allowing additional C-face devices to be mounted to this encoder. Unlike many C-face kit type encoders, the Model 865T contains precision bearings and an internal flex mount, virtually eliminating encoder failures and inaccuracies induced by motor shaft runout or axial endplay. The advanced Opto-ASIC design provides advanced noise immunity necessary for many industrial applications. This encoder is ideal for applications using induction motors and flux vector control. The Model 865T provides speed and position information for drive feedback in a slim profile - only 1.00" thick. The Thru-Bore design allows fast and simple mounting of the encoder directly to the accessory shaft or to the drive shaft of the motor, using the standard motor face (NEMA sizes 56C - 184C). The tough, 316 stainless steel housing resists the corrosion and hazards of a caustic industrial environment.

Common Applications

Motor Feedback, Velocity & Position Control, Conveyors, Variable Speed Drives, Mixing & Blending Motors, Assembly & Specialty Machines

Model 865T Ordering Guide

Blue type indicates price adder options. Not all configuration combinations may be available. Contact Customer Service for details.

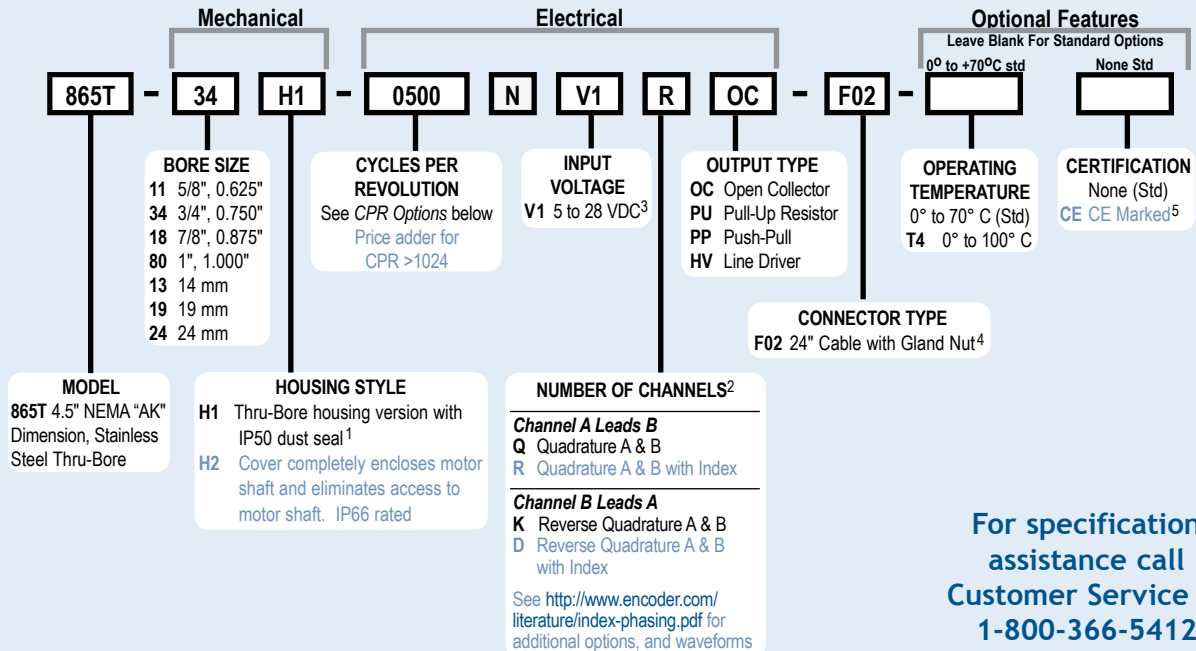

For specification assistance call Customer Service at 1-800-366-5412

Model 865T CPR Options

| | | | | | |
|------|------|------|------|------|------|
| 0060 | 0100 | 0120 | 0240 | 0250 | 0256 |
| 0500 | 0512 | 0600 | 1000 | 1024 | 2048 |
| 2500 | 4096 | | | | |

Contact Customer Service for other disk resolutions; not all disk resolutions available with all output types

NOTES:

- 1 Housing style H1 Thru-Bore version equipped with IP50 dust seal; unit must be mounted between two C-face devices with supplied gasket kit to be IP66 sealed.
- 2 Contact Customer Service for index gating options.
- 3 5 to 24 VDC max for high temperature option.
- 4 For non-standard cable lengths enter 'F' plus cable length expressed in feet. Example: F06 = 6 feet of cable.
- 5 Please refer to Technical Bulletin TB100: *When to Choose the CE Option* at www.encoder.com.

Model 865T

Model 865T Specifications

Electrical

- Input Voltage.....4.75 to 28 VDC max for temperatures up to 70° C
4.75 to 24 VDC for temperatures between 70° C to 100° C
- Input Current.....100 mA max with no output load
- Input Ripple100 mV peak-to-peak at 0 to 100 kHz
- Output Format.....Incremental- Two square waves in quadrature with channel A leading B for clockwise shaft rotation, as viewed from the mounting face. See *Waveform Diagrams* below.
- Output TypesOpen Collector- 100 mA max per channel
Pull-Up- 100 mA max per channel
Push-Pull- 20 mA max per channel
Line Driver- 20 mA max per channel (Meets RS 422 at 5 VDC supply)
- IndexOnce per revolution.
0475 to 4096 CPR: Gated to output A
0001 to 0474 CPR: Ungated
See *Waveform Diagrams* below.
- Max Frequency.....200 kHz
- Noise Immunity.....Tested to BS EN61000-4-2; IEC801-3; BS EN61000-4-4; DDENV 50141; DDENV 50204; BS EN55022 (with European compliance option); BS EN61000-6-2; BS EN50081-2
- Symmetry180°(±18°) electrical
- Quad. Phasing.....90°(±22.5°) electrical
- Min. Edge Sep.....67.5° electrical
- Rise Time.....Less than 1 microsecond

Mechanical

- Max Shaft Speed.....6000 RPM. Higher shaft speeds may be achievable, contact Customer Service.
- Bore Size.....0.625", 0.750", 0.875", 1.000", 14 mm, 19 mm, and 24 mm
- Bore Tolerance+0.0015"/-0.000"
- User Shaft Tolerances
Radial Runout.....0.005"
Axial Endplay.....±0.050"
- Moment of Inertia.....3.3 x 10⁻³ oz-in-sec² typical
- Electrical ConnGland nut with 24" cable (foil and braid shield, 24 AWG conductors)
- Housing.....Type 316 Stainless Steel
- Mounting.....NEMA 56C to 184C
- Weight.....6 lb typical

Environmental

- Operating Temp.....0° to 70° C for standard models
0° to 100° C for high temperature option
- Storage Temp-25° to 100° C
- Humidity.....98% RH non-condensing
- Vibration.....10 g @ 58 to 500 Hz
- Shock.....50 g @ 11 ms duration
- Sealing.....IP66 when mounted between two C-face devices with supplied gasket kit, or with H1 cover. IP50 if not installed in either manner.

Model 865T With Gland Nut (P)

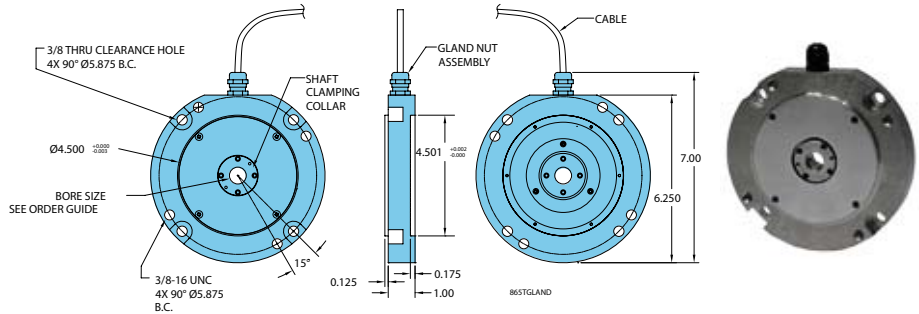

Model 865T Optional Housing Cover (H2)

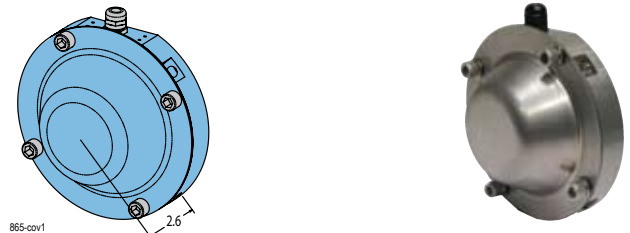

All dimensions are in inches with a tolerance of ±0.005" or ±0.01" unless otherwise specified

Waveform Diagrams

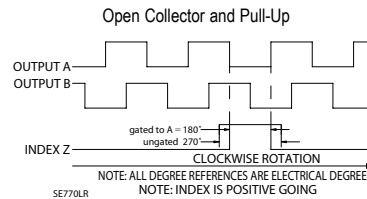
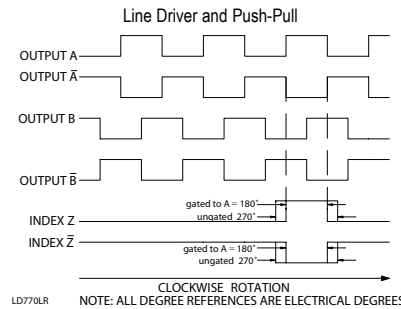

Wiring Table

| Function | Gland Cable Wire Color |
|----------|------------------------|
| Com | Black |
| +VDC | Red |
| A | White |
| A' | Brown |
| B | Blue |
| B' | Violet |
| Z | Orange |
| Z' | Yellow |
| Shield | Bare* |

*CE Option: Cable Shield (bare wire) is connected to internal Case

Stainless Steel Encoders