

REVISIONS		
REV.	DESCRIPTION	DATE
-	INITIAL RELEASE PER ECO 05408	1/15/08

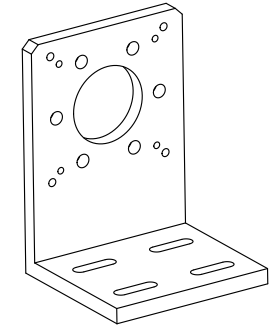
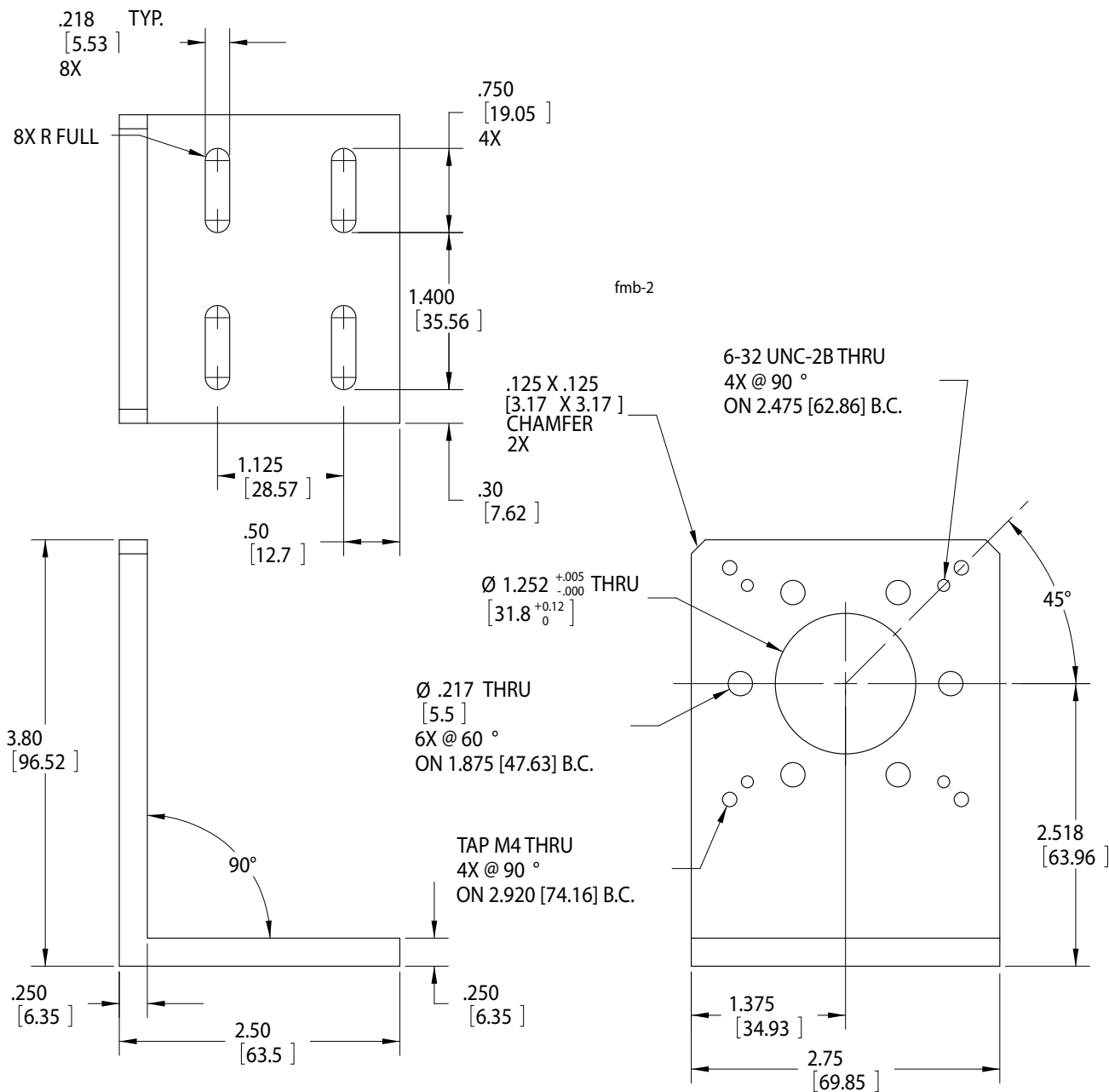

THIRD ANGLE PROJECTION		APPROVALS		DATE	NAME AND TITLE	
		DRAWN	NNP	1/15/08	FOOT MOUNT BRACKET #2	
DIMENSIONS ARE IN INCHES		CHECKED			DWG. NO. <b>fmb-2</b>	
ISSUE DATE	TOLERANCES	RESP ENG			REV.	-
1/15/08	DECIMAL ± .005	MFG ENG				
NEXT ASSEM.	DECIMAL ± .01	QUAL ENG				
140122	ANGULAR ± 1					
SCALE: NONE		DWG. SIZE: B		SHEET 1 OF 1		

www.encoder.com