

Model 25T/H

Incremental Thru/Blind Hollow Bore Encoder

Advanced, versatile, & reliable

The EPC Model 25T/H is designed for high performance in demanding industrial environments, and can serve as a single solution for most 2.0" to 3.5" encoder applications, including HS20, HS25, and HS35 styles.

FEATURES:

- 2.5" Opto-ASIC encoder with low 2.0" profile
- Standard bore sizes from 0.25" to 1.125"
- Metric bore sizes from 6 mm to 28 mm
- Up to 1 MHz maximum frequency
- Resolutions to 10,000 CPR
- Versatile flex mount options
- IP66 sealing available
- Operating temps: -40° C to 105° C

APPLICATIONS

Motor-mounted feedback and vector control, specialty machines, robotics, web process control, paper & printing, high power motors.

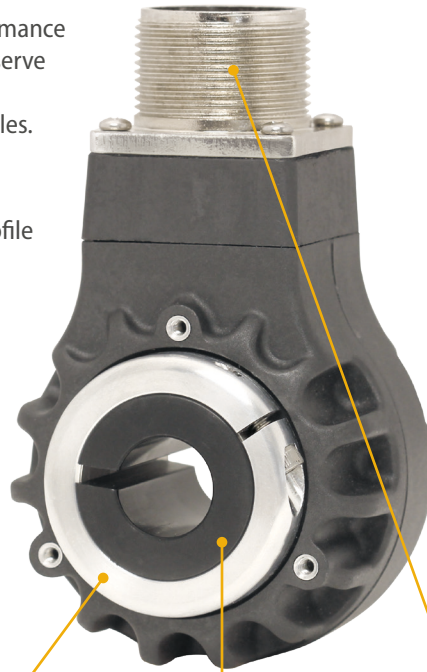

Multiple Output Types

For versatility in new applications or retrofits, the 25T/H can be specified with Open Collector, Push-Pull, Line Driver, or Pull-Up Resistor. A 5V fixed output option is available with Line Driver or Push-Pull.

Disk Resolutions

With resolutions from 1 to 10,000 CPR, the Model 25T/H suits a wide range of application requirements.

IP66 Sealing

IP66 sealing is available for applications where water or heavy, fine dust is present. Standard sealing rating is IP50.

Flex Mount Options

Anti-rotation flex mounts accommodate a variety of mounting requirements for both OEM and retrofit applications.

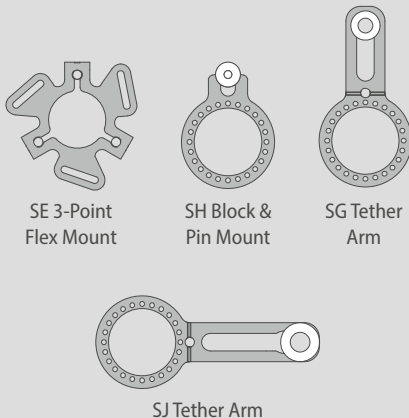

Bore Inserts

Bore insert kits allow the 25T/H to replace several encoders with just one model. Offering 22 bore sizes from 0.25" to 1.125" (6 mm to 28 mm), the non-conducting ULTEM bore insert material provides thermal and electrostatic discharge (ESD) isolation.

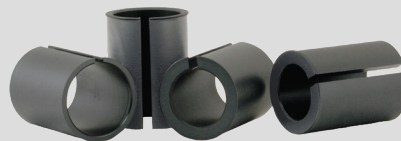

Connector Options

The 25T/H accommodates industry-standard connectors with a wide range of options.

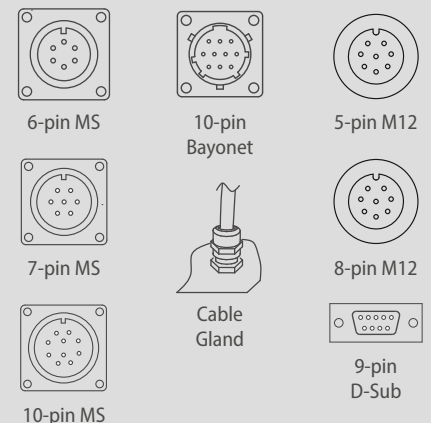

Advanced design for superior performance

ULTEM 1000 Bore Inserts

- Effective thermal barrier
- Protection from ESD

Cooling Fins

- Dissipates heat; protects bearings and electronics
- Design allows for a large 1.125" max bore size

Opto-ASIC Sensing

- Wide sensor to disk air gap
- Stable over broad temp range (-40° C to 105° C)
- Reduced risk of damage from shock and vibration
- Phased-array sensor for clean, reliable signal
- "Board on a chip" design reduces number and size of components

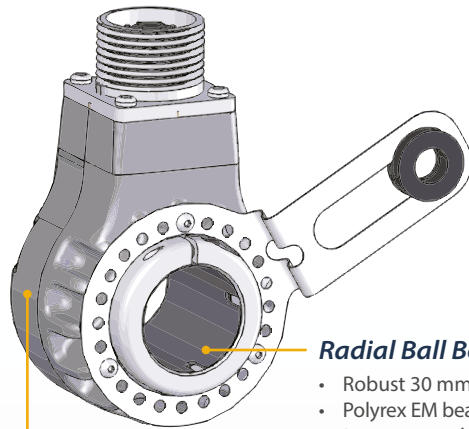
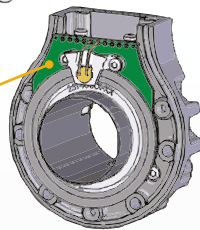
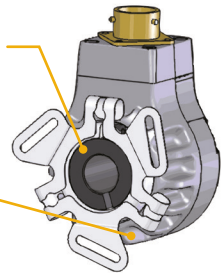

Radial Ball Bearings

- Robust 30 mm internal diameter
- Polyrex EM bearing grease resists high temps, corrosion, and offers noise protection

Composite Housing

- Proprietary high-strength, corrosion-resistant material
- Lightweight housing reduces bearing wear
- Embedded particles provide noise protection

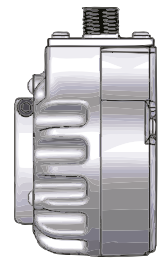

ADDITIONAL OPTIONS

Corrosion Resistance

- Stainless steel M12 connector
- Corrosion resistant gland and cable
- Stainless steel shaft collar and hardware



Motor Kits

- SG tether arm mount
- Mating connector
- 56C protective encoder cover



Magnetic Couplings

- Self-centering magnetic shaft coupling
- Withstands 100 lbs. shear force



MODEL 25T/H SPECIFICATIONS

Electrical

Input Voltage	4.75 to 28 VDC max for temperatures up to 85° C 4.75 to 24 VDC max for temperatures between 85° and 105° C
Input Current	100 mA max with no output load
Output Format	Incremental – Two square waves in quadrature with channel A leading B for clockwise shaft rotation, as viewed from the mounting face.
Output Types	Open Collector – 20 mA max per channel Pull Up – Open Collector with 2.2K ohm internal resistor, 20 mA max per channel Push-Pull – 20 mA max per channel Line Driver – 20 mA max per channel (Meets RS 422 at 5 VDC supply)
Index	Once per revolution. 1 to 360 CPR: Ungated 361 to 10,000 CPR: Gated to output A

Max Frequency	250 kHz for 1 to 2500 CPR 500 kHz for 2501 to 5000 CPR 1 MHz for 5001 to 10,000 CPR
Electrical Protection	Reverse voltage and output short circuit protected. NOTE: Sustained reverse voltage may result in permanent damage.
CE Testing	Emissions tested per EN61000-6-3:2001 as applicable. Immunity tested per EN6100-6-2: 2005 as applicable.
Min. Edge Sep.	45° electrical min, 63° electrical or better typical
Rise Time	Less than 1 microsecond
Accuracy	Within 0.1° mechanical from one cycle to any other cycle, or 6 arc minutes.

Mechanical

Max Shaft Speed	6000 RPM, 8000 RPM intermittent 4000 RPM for IP66 seal option
Bore Tolerance	-0.0000"/+0.0008"

User Shaft Tolerances

Radial Runout	±0.005" max
Axial Endplay	±0.050" max
Starting Torque	IP50 sealing: 1.0 oz-in typical IP66 sealing: 4.0 oz-in typical Note: Add 1.0 oz-in typical for -20° C operation
Moment of Inertia	7.6 x 10 ⁻⁴ oz-in-sec ²
Housing	Proprietary nylon composite
Weight	8 oz typical

Environmental

Storage Temp	-20° to 85° C
Humidity	98% RH non-condensing
Vibration	20 g @ 5 to 2000 Hz
Shock	80 g @ 11 ms duration
Sealing	IP50, IP66 with shaft seals at both ends

Not sure which motion feedback is right for your application? Give us a call. When you call EPC, you talk to engineers and encoder experts who can help you specify the right encoder solution for your motion control application. Contact EPC today.

