

WAVEFORM DIAGRAMS

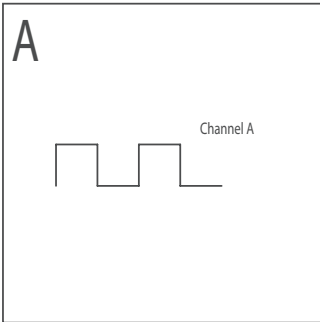

Figure 1: Single channel only

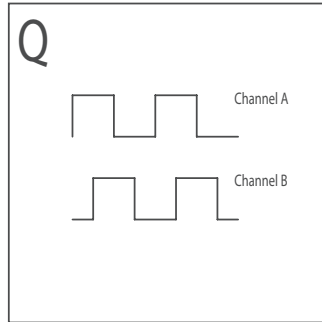

Figure 2: Quadrature A and B

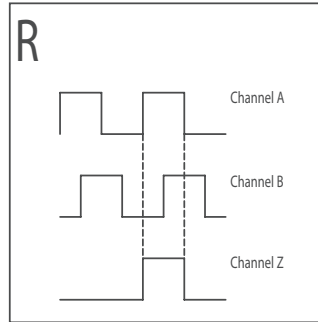

Figure 3: Quadrature A and B with 180° Index gated to A

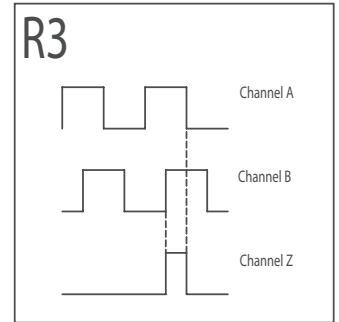

Figure 4: Quadrature A and B with 90° Index gated to A and B

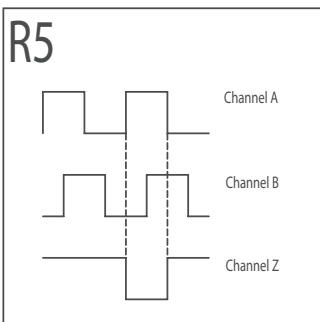

Figure 5: Quadrature A and B with inverted 180° Index gated to A

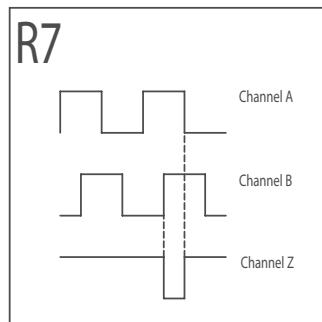

Figure 6: Quadrature A and B with inverted 90° Index gated to A and B

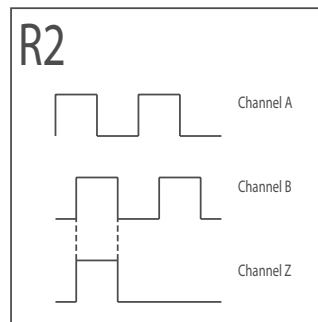

Figure 7: Quadrature A and B with 180° Index gated to B

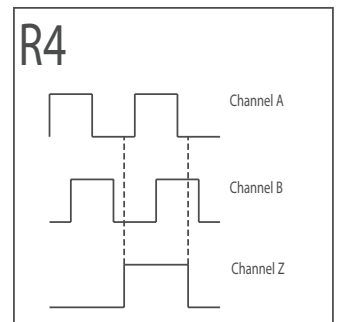

Figure 8: Quadrature A and B with ungated Index centered on A between 360° and 180°

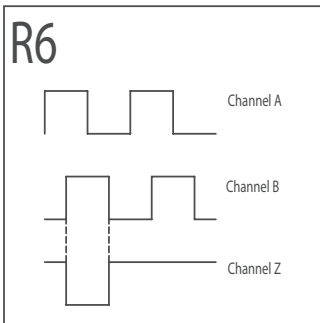

Figure 9: Quadrature A and B with inverted 180° Index gated to B

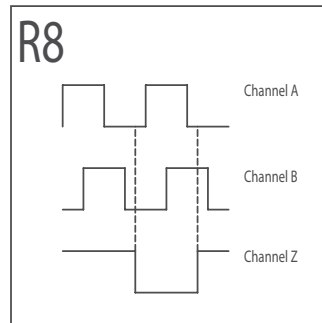

Figure 10: Quadrature A and B with ungated inverted Index centered on A between 360° and 180°

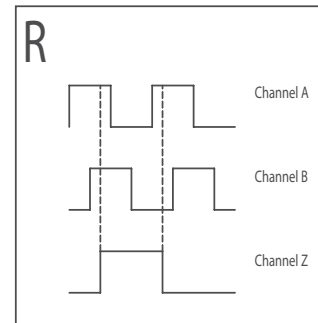

Figure 11: Quadrature A and B with ungated Index centered on A low between 360° and 180°

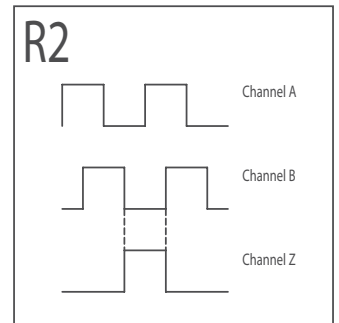

Figure 12: Quadrature A and B with 180° Index gated to B low

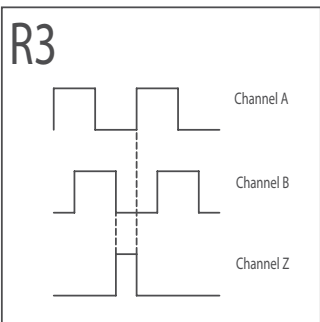

Figure 13: Quadrature A and B with 90° Index gated to A low and B low

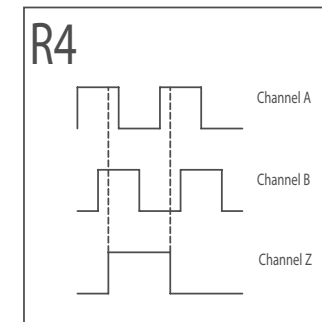

Figure 14: Quadrature A and B with ungated Index centered on A low between 360° and 180°

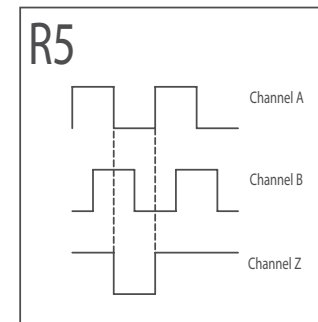

Figure 15: Quadrature A and B with inverted 180° Index gated to A low

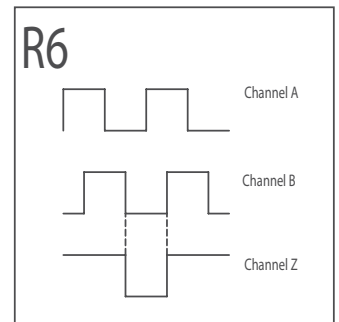

Figure 16: Quadrature A and B with inverted 180° Index gated to B low

WAVEFORM DIAGRAMS

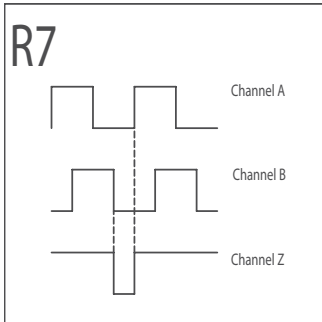

Figure 17: Quadrature A and B with inverted 90° Index gated to A low and B low

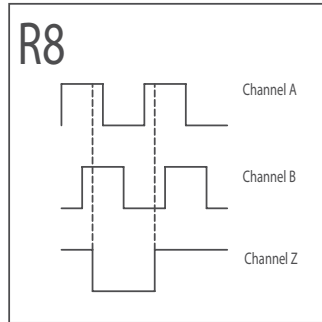

Figure 18: Quadrature A and B with ungated inverted Index centered on A low between 360° and 180°

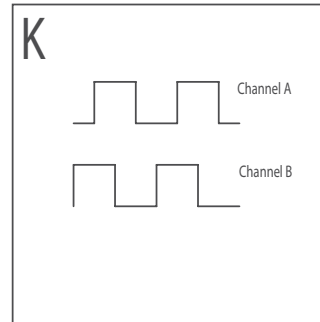

Figure 19: Reverse Quadrature A and B

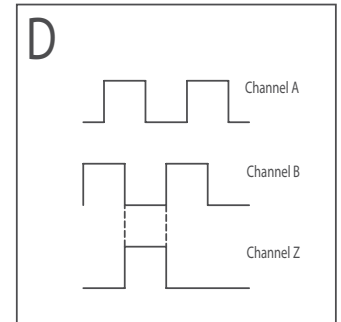

Figure 20: Reverse Quadrature A and B with 180° Index gated to B low

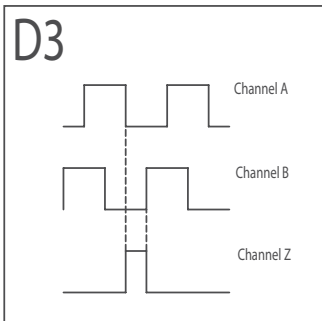

Figure 21: Reverse Quadrature A and B with 90° Index gated to A low and B low

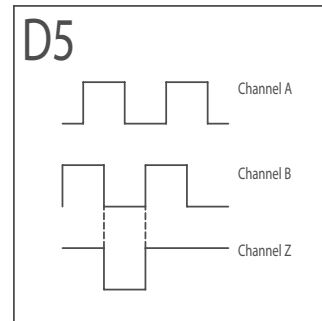

Figure 22: Reverse Quadrature A and B with inverted 180° Index gated to B low

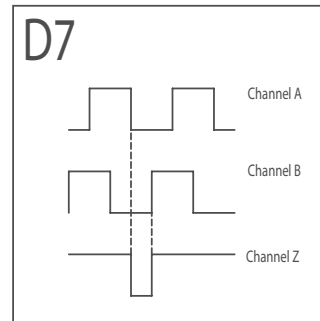

Figure 23: Reverse Quadrature A and B with inverted 90° Index gated to A low and B low

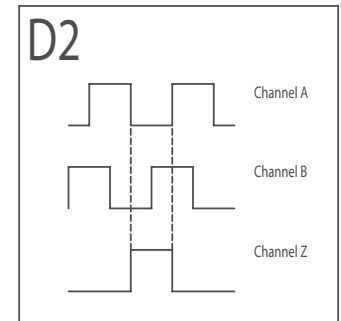

Figure 24: Reverse Quadrature A and B with 180° Index gated to A low

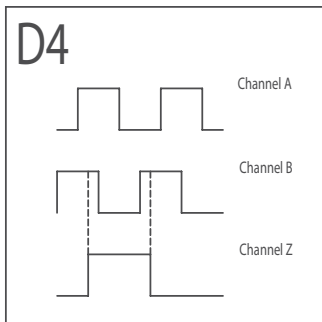

Figure 25: Reverse Quadrature A and B with ungated Index centered on B low between 360° and 180°

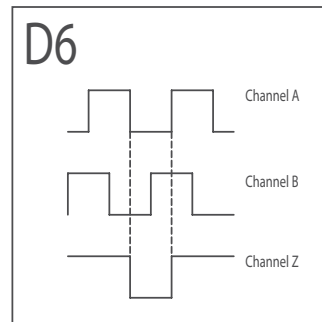

Figure 26: Reverse Quadrature A and B with inverted 180° Index gated to A low

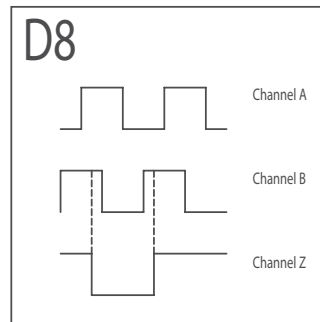

Figure 27: Reverse Quadrature A and B with ungated and inverted Index centered on B low between 360° and 180°

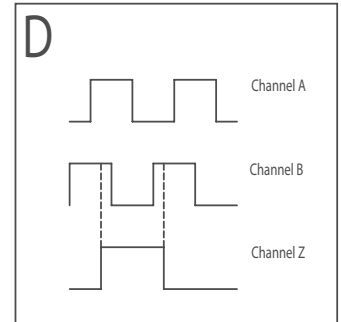

Figure 28: Reverse Quadrature A and B with ungated Index centered on B low between 360° and 180°

Call Sales & Customer Service at 800-366-5412

EPC is open for business from

8:00 am to 7:30 pm Eastern Time/ 5:00 am to 4:30 pm Pacific Time