

## MODEL 776 - INCREMENTAL ENCODER



Ø4.3"

### FEATURES

- Slim profile – Only 1.36" in depth
- Thru-bore design for easy mounting
- Incorporates Opto-ASIC technology
- Resolutions to 4096
- Bore options to 1.875"
- CE marking available

The Thru-Bore Series Accu-Coder™ Model 776 encoder is designed to fit directly on either a motor or other shaft where position, direction, or velocity information is needed. The advanced Opto-ASIC based electronics provide the superior noise immunity necessary in many industrial applications. The Model 776 conveniently features a clamp type mount for fast and easy mounting over a large range of shaft sizes. An optional anti-rotation flex mount maintains housing stability.

### COMMON APPLICATIONS

Motor Feedback, Velocity & Position Control, Robotics, Conveyors, Material Handling

### MODEL 776 ORDERING GUIDE

Blue type indicates price adder options. Not all configuration combinations may be available. Contact Customer Service for details.

<b>776</b>	<b>A</b>	<b>H</b>	<b>1024</b>	<b>Q</b>	<b>OC</b>	<b>C</b>	<b>Y</b>	<b>N</b>	<b>N</b>	<b>CE</b>
<b>MODEL</b> 776 Slim thru-bore	<b>OPERATING TEMPERATURE</b> S 0° to 70° C H 0° to 100° C	<b>HOUSING STYLE</b> A Completely encloses motor shaft, and eliminates access to motor shaft. For physical protection only. B Thru-bore housing version. Allows access to motor shaft.	<b>NUMBER OF CHANNELS<sup>1</sup></b> Channel A leads B Q Quadrature A & B R Quadrature A & B with Index Channel B leads A K Reverse quadrature A & B D Reverse quadrature A & B with Index See <a href="#">Quadrature Phasing &amp; Index Gating Options</a> at <a href="#">encoder.com</a> for additional options and waveforms	<b>BORE SIZE</b> G 1-7/16", 1.4375" C 1-1/2", 1.500" D 1-5/8", 1.625" F 1-3/4", 1.750" E 1-7/8", 1.875" L 35 mm I 38 mm J 40 mm M 42 mm N 43 mm	<b>ANTI-ROTATION FLEX MOUNT</b> N None A Style A	<b>CERTIFICATION</b> N None CE CE marked <sup>7</sup>	<b>MATING CONNECTOR</b> N No connector Y Yes	<b>CYCLES PER REVOLUTION</b> 1 - 4096 See <a href="#">CPR Options</a> below for available resolutions Price adder for CPR > 1024	<b>OUTPUT TYPE</b> 5 - 28V In / Out <sup>2</sup> OC Open Collector PU Pull-Up Resistor PP Push-Pull HV Line Driver <sup>3</sup>	<b>CONNECTOR TYPE<sup>4</sup></b> P Gland nut with 24" cable <sup>5</sup> W 6-pin MS <sup>3, 6</sup> Y 7-pin MS <sup>3, 6</sup> X 10-pin MS <sup>6</sup> J 5-pin M12 (12 mm) <sup>3, 6</sup> K 8-pin M12 (12 mm) <sup>6</sup> 9D 9-pin D-subminiature

### MODEL 776 CPR OPTIONS

0060	0100	0120	0240
0250	0256	0500	0512
1000	1024	2048	2500
4096			

Contact Customer Service for other disk resolutions; not all disk resolutions available with all output types

### NOTES:

- Contact Customer Service for index gating options.
- 5 to 24 VDC max for high temperature option.
- Line Driver not available with 5-pin M12 or 6-pin MS connector. Available with 7-pin MS connector only without Index Z.
- For mating connectors, cables, and cordsets see [Accessories](#) at [encoder.com](#). For Connector Pin Configuration Diagrams, see Technical Information or see [Connector Pin Configuration Diagrams](#) at [encoder.com](#).
- For non-standard cable lengths, add a forward slash (/) plus cable length expressed in feet. Example: P/6 = 6 feet of cable.
- Connector options other than 9D and P require extended housing. See drawing, next page.
- Please refer to Technical Bulletin [TB100: When to Choose the CE Mark](#) at [encoder.com](#).

## MODEL 776 - INCREMENTAL ENCODER

### MODEL 776 SPECIFICATIONS

#### Electrical

Input Voltage.....	4.75 to 28 VDC max for temperatures up to 70° C
.....	4.75 to 24 VDC for temperatures between 70° C and 100° C
Input Current.....	100 mA max with no output load
Input Ripple.....	100 mV peak-to-peak at 0 to 100 kHz
Output Format.....	Incremental – Two square waves in quadrature with channel A leading B for clockwise shaft rotation, as viewed from the mounting face. See Waveform Diagrams.
Output Types.....	Open Collector – 100 mA max per channel
.....	Pull-Up – Open Collector with 2.2K ohm internal resistor, 100 mA max per channel
.....	Push-Pull – 20 mA max per channel
.....	Line Driver – 20 mA max per channel (Meets RS 422 at 5 VDC supply)
Index.....	Once per revolution.
.....	.0513 to 4096 CPR: Gated to output A
.....	.0001 to 0512 CPR: Ungated
.....	See Waveform Diagrams.
Max Frequency.....	200 kHz
Electrical Protection.....	Reverse voltage and output short circuit protected. NOTE: Sustained reverse voltage may result in permanent damage.
Noise Immunity.....	Tested to BS EN61000-4-2; IEC801-3;
.....	BS EN61000-4-4; DDENV 50141; DDENV 50204; BS EN55022 (with European compliance option);
.....	BS EN61000-6-2;
.....	BS EN50081-2
Quadrature.....	67.5° electrical or better is typical,
Edge Separation.....	54° electrical minimum at temperatures > 99° C
Rise Time.....	Less than 1 microsecond

#### Mechanical

Max Shaft Speed.....	3500 RPM. Higher shaft speeds may be achievable, contact Customer Service.
User Shaft Tolerances	
Radial Runout.....	0.005"
Axial Endplay.....	+0.030" with appropriate flex mount
Moment of Inertia.....	$3.3 \times 10^{-3}$ oz-in-sec <sup>2</sup> typical
Housing.....	All metal construction
Weight.....	1.0 lb with gland nut or D-sub connector option 1.5 lb with MS connector option. Note: All weights typical

#### Environmental

Storage Temp.....	-25° to 100° C
Humidity.....	98% RH non-condensing
Vibration.....	10 g @ 58 to 500 Hz
Shock.....	50 g @ 11 ms duration
Sealing.....	IP50

## MODEL 776 - INCREMENTAL ENCODER

### MODEL 776 WITH GLAND NUT CABLE (P)

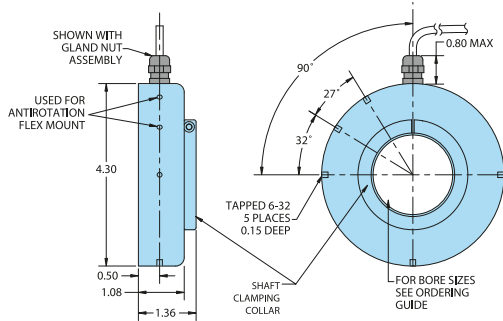

### MODEL 776 WITH 9-PIN D-SUB CONNECTOR (9D)

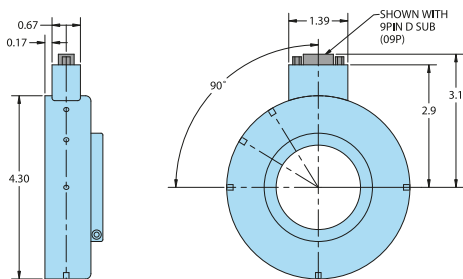

### MODEL 776 EXTENDED HOUSING (W, X, Y, J, K)

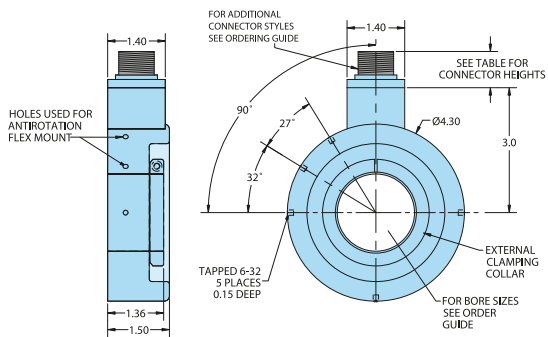

Connector Type	Height
6- or 7-pin MS	0.67"
10-pin MS	0.90"
5- or 8-pin M12	0.50"

### MODEL 776 SHOWN WITH ANTI-ROTATION FLEX MOUNT

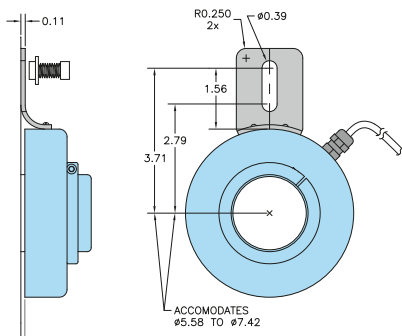

## MODEL 776 - INCREMENTAL ENCODER

### WIRING TABLE

For EPC-supplied mating cables, refer to wiring table provided with cable.  
Trim back and insulate unused wires.

Function	Gland Cable Wire Color†	5-pin M12 <sup>++</sup> PU, PP, OC	8-pin M12 <sup>++</sup>	10-pin MS	7-pin MS HV	7-pin MS PU, PP, OC	6-pin MS PU, PP, OC	9-pin D-sub
Com	Black	3	7	F	F	F	A, F	9
+VDC	Red	1	2	D	D	D	B	1
A	White	4	1	A	A	A	D	2
A'	Brown	--	3	H	C	--	--	3
B	Blue	2	4	B	B	B	E	4
B'	Violet	--	5	I	E	--	--	5
Z	Orange	5	6	C	--	C	C	6
Z'	Yellow	--	8	J	--	--	--	7
Case	--	--	--	G <sup>**</sup>	G <sup>**</sup>	G <sup>**</sup>	--	8 <sup>+</sup>
Shield	Bare*	--	--	--	--	--	--	--

\*CE Option: Cable shield (bare wire) is connected to internal Case.

\*\*CE Option: Pin G is connected to Case. Non-CE Option: Pin G has No Connection.

+CE Option: Pin G is connected to Case. Non CE Option: Pin 8 has No Connection.

++CE Option: Use cable cordset with shield connected to M12 connector coupling nut.

†Standard cable is 24 AWG conductors with foil and braid shield.

### WAVEFORM DIAGRAMS

#### Line Driver and Push-Pull

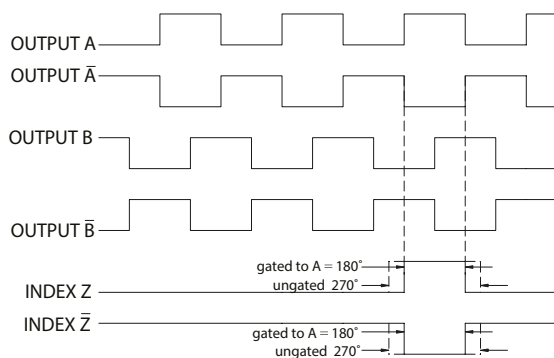

Clockwise rotation as viewed from the mounting face.

NOTE: All degree references are electrical degrees.

Waveform shown with optional complementary signals.

A, B, Z for HV output only.

#### Open Collector and Pull-Up

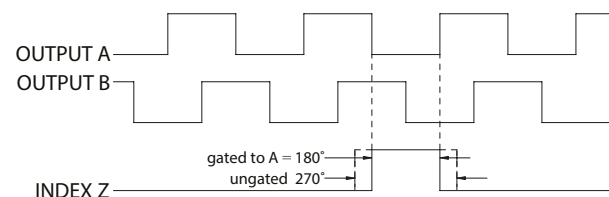

Clockwise rotation as viewed from the mounting face.

NOTE: All degree references are electrical degrees. Index is positive going.