

SHAFT SIZE	ØD	L1	d	L2
6mm	6 [0.236]	12 [0.472]	0.70 [0.028]	10 [0.394]
10mm	10 [0.394]	20 [0.787]	no flat	n/a

REVISIONS			
REV.	DESCRIPTION	APPR.	DATE
A	INITIAL RELEASE	07938	2/16/2021
B	UPDATED DIMENSION OF THRU HOLES	08065	4/26/2021

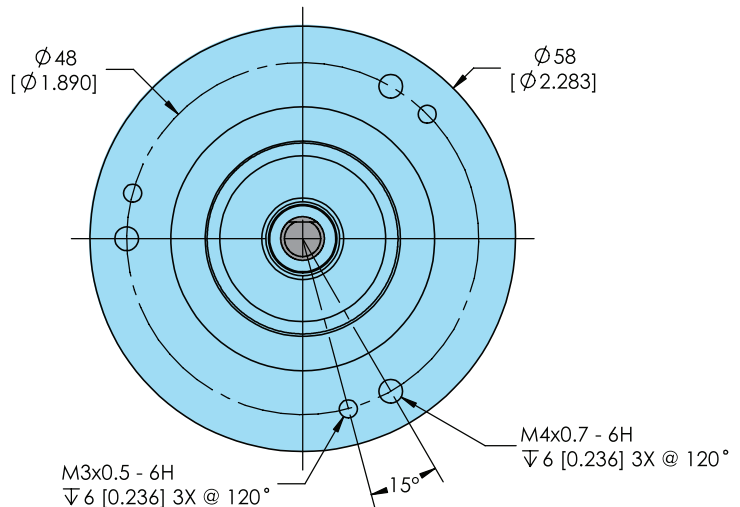
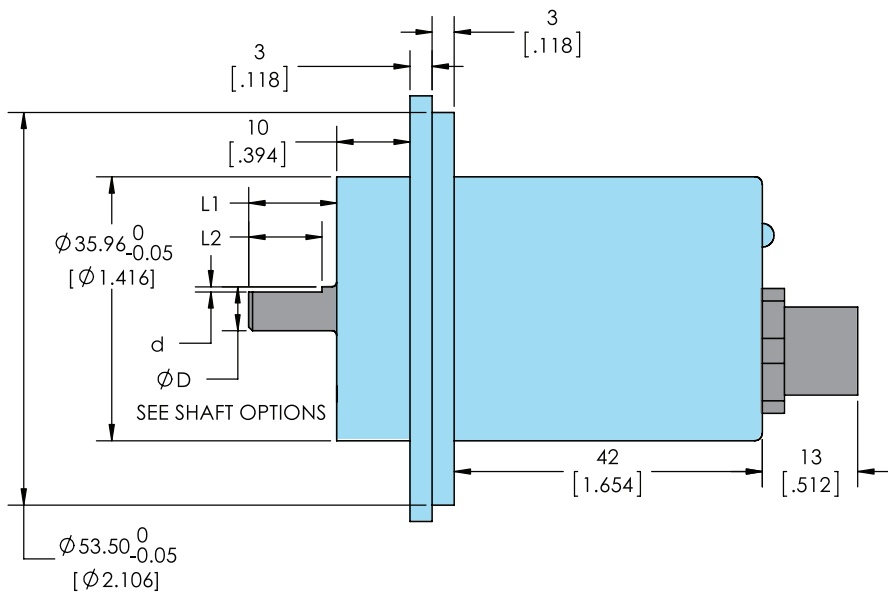

NOTE:
Primary dimensions are in mm, secondary dimensions [inches] in brackets for reference only.

THIRD ANGLE PROJECTION		ENCODER PRODUCTS COMPANY		www.encoder.com	
DIMENSIONS ARE IN mm		APPROVALS	DATE	NAME AND TITLE	
ISSUE DATE:	TOLERANCES	DRAWN	CHECKED	A58SB-CLAMPING FLANGE, AXIAL CONNECTOR	
2/16/2021		MJW	06/17/20		
NEXT ASSEM.	DECIMAL ± .13	RESP ENG		DWG. NO.	
PREV. ASSEM.	DECIMAL ± .3	MFG ENG		A58SB-MH-AXIAL CONN	
PART NUMBER	ANGULAR ± 1	QUAL ENG		REV.	B
				SCALE: NONE	DWG. SIZE: B
				SHEET 1 OF 1	