

| SHAFT SIZE | ØD | L1 | d | L2 |
|------------|------------|------------|-------------|------------|
| 6 mm | 6 [0.236] | 12 [0.472] | 0.7 [0.028] | 10 [0.394] |
| 10 mm | 10 [0.394] | 20 [0.787] | no flat | n/a |

| REVISIONS | | | |
|-----------|-----------------------|-------|-----------|
| REV. | DESCRIPTION | APPR | DATE |
| A | INITIAL RELEASE | 07938 | 2/16/2021 |
| B | HOUSING DESIGN CHANGE | 08065 | 4/26/2021 |

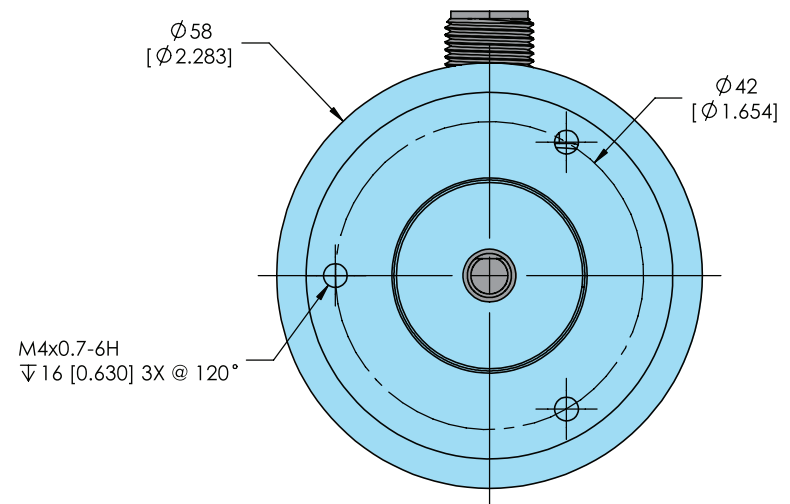
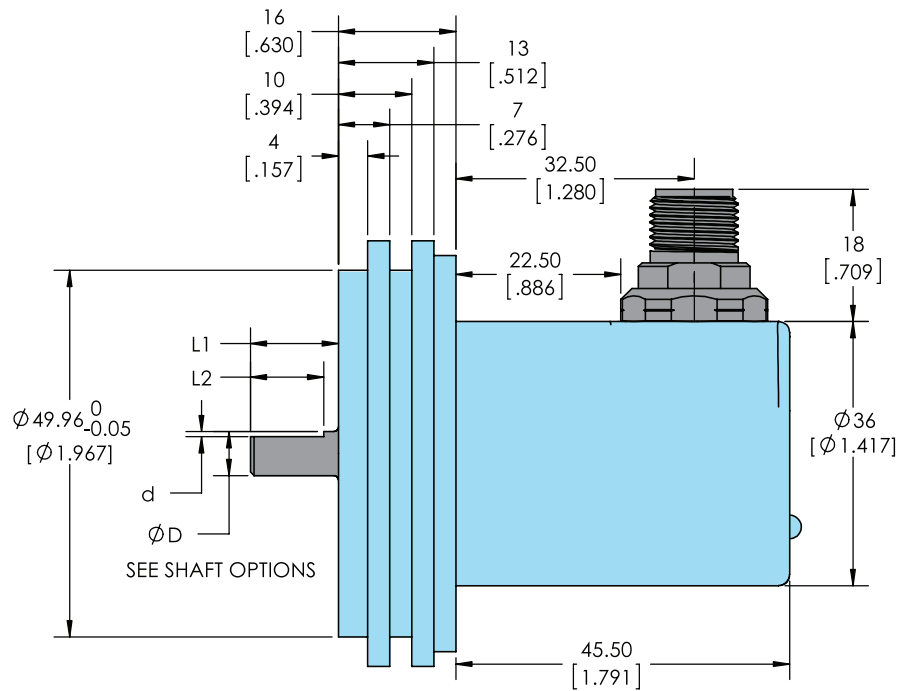

NOTE:
Primary dimensions are in mm, secondary dimensions [inches] in brackets for reference only.

| THIRD ANGLE PROJECTION | | ENCODER PRODUCTS COMPANY | | www.encoder.com | |
|------------------------|------------|--------------------------|---------|---|--------------|
| DIMENSIONS ARE IN mm | | APPROVALS | DATE | NAME AND TITLE | |
| ISSUE DATE: | TOLERANCES | DRAWN | CHECKED | A58SB-SYNCHRO FLANGE, RADIAL CONNECTOR | |
| NEXT ASSEM. | DECIMAL | RESP ENG | | DWG. NO. | |
| PREV. ASSEM. | DECIMAL | MFG ENG | | A58SB-MK-RADIAL CONN | |
| PART NUMBER | ANGULAR | QUAL ENG | | SCALE: NONE | REV. B |
| | | | | DWG. SIZE: B | SHEET 1 OF 1 |