

MODEL A58HE - ETHERNET ABSOLUTE ENCODER

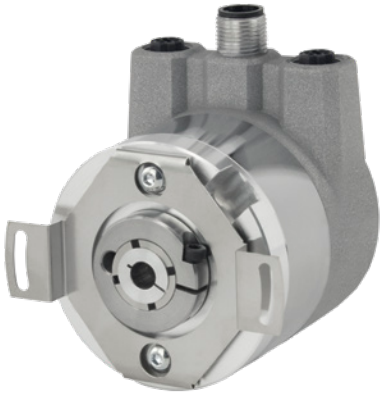

Ø58 mm



FEATURES

- Single Turn/Multi-Turn Absolute Encoder (16 Bit ST / 43 Bit MT)
- Available in two industrial Ethernet protocols:
 - EtherCAT® with CoE, FoE, EoE – device profile: CiA DS-406 V4.0.2, Class 3
 - PROFINET® I-O (CC-C) – device profile: switchable V4.1, Class 3, 4
- Maintenance-free and environmentally friendly magnetic design
- Energy harvesting magnetic multi-turn technology
- No gears or batteries
- Low TCO and easy provisioning with internal web server
- Color LEDs for operating condition, bus status, link activity
- Compact design with bus cover
- 58 mm (2.28") diameter package

The Model A58HE is an EtherCAT or PROFINET-ready, multi-turn absolute encoder designed for harsh factory and plant environments. It is particularly suited to applications where Ethernet-based connectivity is required, and the encoder must retain position information after power-off events. Easily designed into a wide variety of system applications, the Model A58HE plugs directly into your network with minimal provisioning for rapid deployment, facilitating data exchange among myriad networked devices. The Model A58HE retains absolute position information even after a power loss, facilitating speedy system recovery at start-up without the need for system re-homing.

Ready for Industry 4.0 and for the Industrial Internet of Things (IIoT), data exchange between the Model A58HE and other applications has no influence on the control loop. The Model A58HE is non-reactive and can work independently from the PLC or master, transferring data through network gateways to other automation networks and sites, and up to the cloud for analysis.

COMMON APPLICATIONS

Robotics, Telescopes, Antennas, Medical Scanners, Wind Turbines, Elevators, Lifts, Motors, Automatic Guided Vehicles, Rotary and X/Y Positioning Tables

MODEL A58HE ORDERING GUIDE

Blue type indicates price adder options

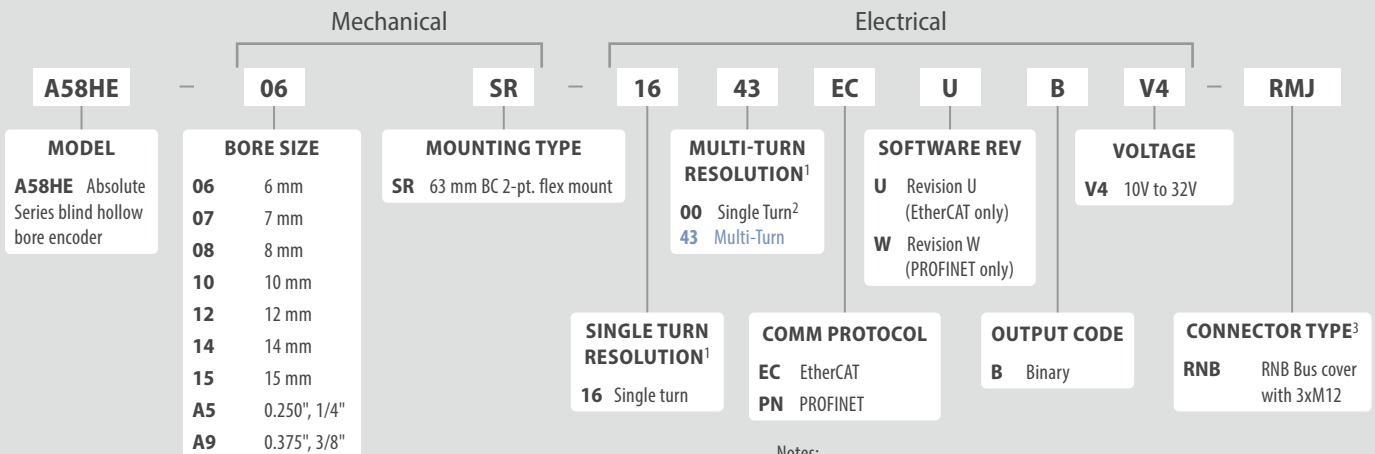

EtherCAT (Ethernet for Control and Automation Technology) is a registered trademark and patented technology, licensed by Beckhoff Automation GmbH, Germany.
 PROFINET is a registered trademark and patented technology, licensed by PI (PROFIBUS & PROFINET International).

Notes:

- Customer configures at setup.
- Single turn encoders cannot be configured for multi-turn resolution
- For mating connectors, cables, and cordsets see [Accessories](#) at encoder.com

MODEL A58HE - ETHERNET ABSOLUTE ENCODER

MODEL A58HE SPECIFICATIONS

Electrical

Power Supply 10 VDC up to 32 VDC
 Current Consumption.....typ. 125 mA
 Power Consumption.....typ. 3 W

Sensor Specification

Internal Cycle Time50 μ s
 Resolution
 Single Turn.....up to 65,536 steps/360° (16 bit)
 Multi-Turn.....43 bit
 Accuracy
 Single Turn..... $\pm 0.0878^\circ$ (≤ 12 bit)
 Single Turn, Repeat Accuracy .. $\pm 0.0878^\circ$ (≤ 12 bit)
 Technology
 Single Turn.....Innovative Hall-sensor technology
 Multi-Turn.....Patented energy-harvesting technology, no battery and no gears
 Turn on time.....< 1.5 s

Interface

Interface.....Industrial Ethernet
 Protocol.....EtherCAT or PROFINET-IO (CC-C)
 Device Profile.....EtherCAT: CiA DS-406 V4.0.2, Class 3;
PROFINET: V4.1, Class 3, 4
 Data Transfer100BASE-TX
 Cycle time.....EtherCAT: up to 50 μ s
PROFINET: 250 μ s, applicable for up to 125 μ s
 CodeBinary, CW default, programmable
 Programmable Parameters ...Steps per revolution; counts of revolution; preset; scale; counting direction
EtherCAT: 2x 8 cam switches; DC-Mode
PROFINET: MRPD; MRP; LLDP; IRT
 Diagnostic LED.....Traffic and connection management:
L/A1: Port 1 (IN) L/A2: Port 2 (OUT)
 Status LEDSTAT, MOD: status of encoder and bus

Mechanical

FlangeBlind hollow bore
 Flange MaterialAluminum
 Shaft Material.....Stainless steel
 Shaft Length.....17 mm
 Insertion depth
 min.....10 mm
 max19 mm
 Housing CapSteel case chrome-plated, magnetic shielding
 Connection Cover.....Die cast aluminum, powder coated
 Weight14.462 oz / 410 g approx
 Shaft RotationBi-directional
 Max Radial Shaft Load80 N (17.9 lb)
 Max Axial Shaft Load50 N (11.2 lb)
 Starting Torque.....Approximately 1.6 Ncm (2.226 oz-in) at ambient temperature.
 Max Shaft Speed.....6000 RPM
 Bearings Type2 precision ball bearings
 Nominal Service Life1 x 10⁹ revs. at 100% rated shaft load
1 x 10¹⁰ revs. at 40% rated shaft load
1 x 10¹¹ revs. at 20% rated shaft load

Environmental

Operating Temp.....-40° to 85° C
 Storage Temp.....-40° to 100° C
 SealingIP65 tested per EN 60529
 ESD.....8 kV tested per EN 61000-4-2
 Burst2 kV tested per 61000-4-4
 EMC.....EN 61000-6-2; EN 61000-6-3
 Vibration200 m/s² (10 Hz up to 1000 Hz)
(20.3 g [10Hz up to 1000 Hz])
tested per EN 60068-2-6
 Shock5000 m/s² (6 ms)
509.8 g (6 ms)
tested per EN 60068-2-27
 Design.....According to DIN VDE 0160

NETWORK BUS CONNECTOR PINOUT

Bus cover with 3x M12x1. For EPC-supplied mating cables, wiring table is provided with cable. Trim back and insulate unused wires.

Female Connector
Port1 (IN)



Function	M12x1, 4-pin, D-coded
Tx+	1
Rx+	2
Tx-	3
Rx-	4

Power

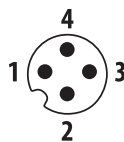

Function	M12x1, 4-pin, A-coded
(+) Vcc	1
n. c.	2
GND	3
n. c.	4

Female Connector
Port2 (OUT)

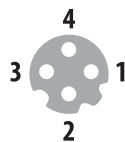

Function	M12x1, 4-pin, D-coded
Tx+	1
Rx+	2
Tx-	3
Rx-	4

MODEL A58HE - ETHERNET ABSOLUTE ENCODER

MODEL A58HE 63 MM 2 PT. FLEX MOUNT (SR)

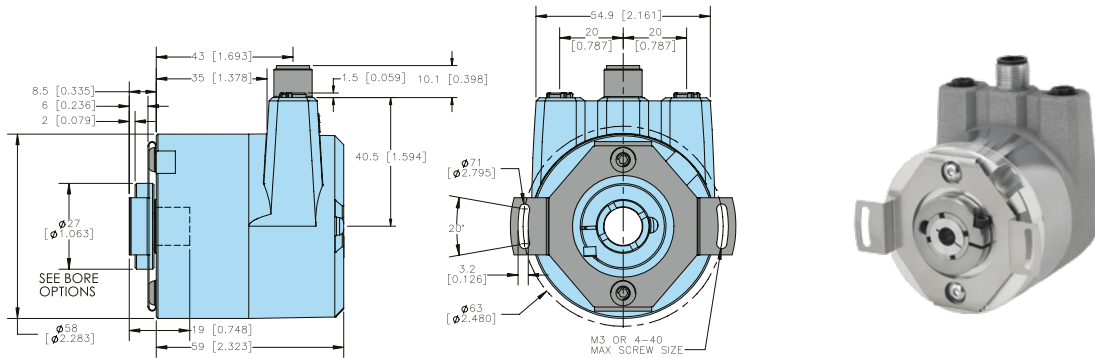

Primary dimensions are in mm, secondary dimensions SI units [inches] in brackets for reference only.

EPC RESERVES THE RIGHT TO UPDATE, REVISE AND AMEND ALL SOFTWARE AND TECHNICAL DATA OR CONTENT AT ANY TIME. EPC SHALL HAVE NO LIABILITY OF ANY KIND OR NATURE FOR ANY TECHNICAL ERRORS OR OMISSIONS IN ANY SOFTWARE OR TECHNICAL DATA. See encoder.com for more information.