

TB-102: Index Gating Options

Encoder Products Company (EPC) offers several index pulse gating options on most encoder models.

The index pulse is also referred to as the reference, marker pulse, or home pulse. This pulse is an individual output channel provided by the encoder that provides a single pulse once per revolution. It simply notes some discrete and fixed position in the mechanical rotation of the unit. Sometimes it is used with a counter to indicate the total number of revolutions the shaft has rotated, counting one pulse per revolution. Often it is used to reset a counter if the counter needs to be reset to zero at the end of each encoder shaft revolution. Quite often it is used in servo applications where total system synchronism is required. Once every revolution, if everything agrees with the position feedback, the system knows it is still operating correctly. Or a system can return to a known physical position aligned with the index pulse.

EPC's standard reference option is once per revolution centered over channel A. For the HV output option, the index is normally gated to channel A and is 180 degrees wide, known as "half-cycle gating". We also have the ability to gate the index pulse to the B channel, or to both A and B channels if required. An index gated to both A and B will result in a 90 degree wide index pulse, known as "quarter-cycle gating". This option allows more precise positioning of the index. However, keep in mind that with a narrower index pulse comes the possibility that the device the encoder is connected to may not see the pulse because it happens so quickly. Please note that these comments regarding the encoder index pulse ONLY apply to units with an "R" or "D" in their part number, which call out A, B, & Z channels. Units with "A", "Q", or "K" in their part number do not provide an index pulse. Non-standard gating options are available, but must be requested by the customer at the time of ordering.

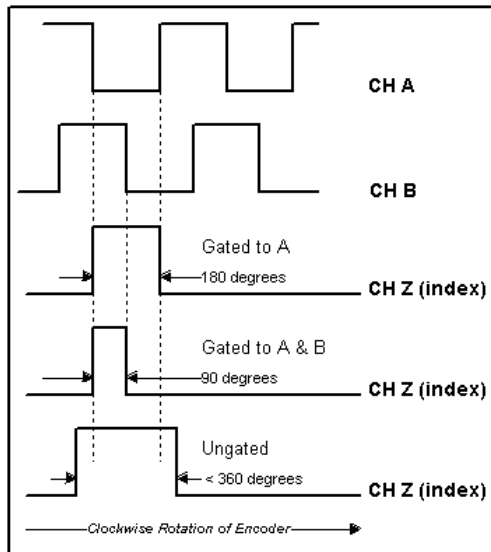

Diagram of index pulses for Accu-Coder™ encoders that have a positive index following a negative Channel A.

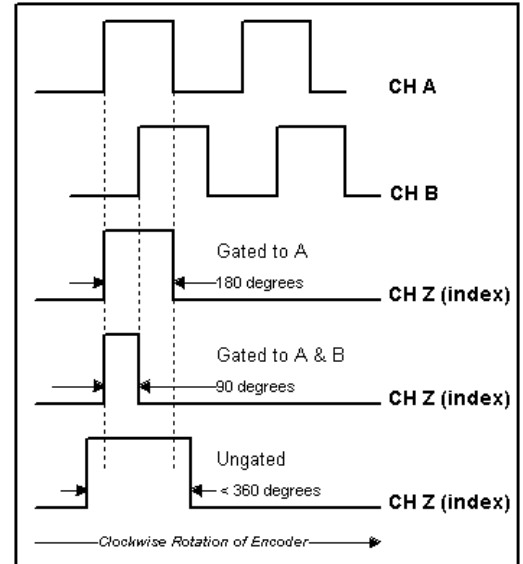

Diagram of index pulses for Accu-Coder™ encoders that have a positive index following a positive Channel A.

Most index pulses are related to electrical degrees, but some are mechanically derived. These are comprised of a disc with the index pulse etched onto this disk in addition to the main count channels. This type of index is usually referenced to a particular count channel such as "A". It is normally not gated; however, it can be done on occasions. By making this etched aperture a certain width, the resulting pulse width of the index can be varied. Remember that the actual pulse "width" is a function of time, and the width will vary as an inverse function of rotational shaft speed. One use for lengthened mechanical index pulses is for resetting counters that have long reset time periods. Also, by gating to the count channel, the encoder output can be inhibited for a period of time while the index pulse is active. This is commonly used in the packaging industry, where counts are not desired while the container is being filled and is moving to the next processing station.