

771 Mounting Instructions

After carefully unpacking the unit, inspect and ensure that the motor shaft is the correct size and free of all burrs and aberrations.

Maximum recommended motor axial endplay is $\pm 1/10"$. Maximum motor shaft total indicated runout (TIR) is 0.005".

STEP 1

This step is for housing cover option A only.

Remove $\frac{1}{2} \times 13 \times \frac{3}{4}$ " bolts and washers from cover of tapped holes of C-face housing.

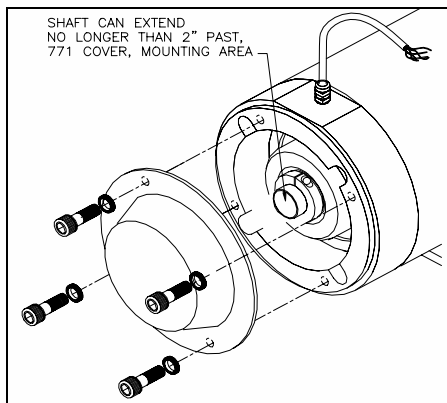

STEP 2

1. Slide the Model 771 encoder over the motor shaft.

DO NOT USE UNDUE FORCE.

2. If the encoder does not slide on easily, make sure that the clamping screw is loose and remove burrs from the shaft with fine crocus paper.

3. Install $\frac{1}{2} \times 13 \times 2$ " hex bolts and washers through C-face housing.

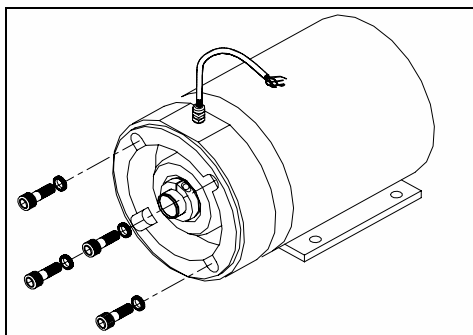

STEP 3

1. The encoder is positioned in the center of the C-face housing to accommodate axial movement of the motor shaft.

2. Lay a straight edge across the front of the encoder C-face housing.

3. Using the straight edge for a reference, position the encoder so that the front edge of the clamping collar is the following specified distance from the front C-face surface:

- 0.10" for shaft diameters greater than 1.375".
- 0.18" for shaft diameters less than or equal to 1.375".

4. Tighten the hex head screw in the clamping collar.

5. Make sure the screw is securely tightened.

6. When the motor shaft is turned by hand or operated, the movement in the encoder should be very minimal.

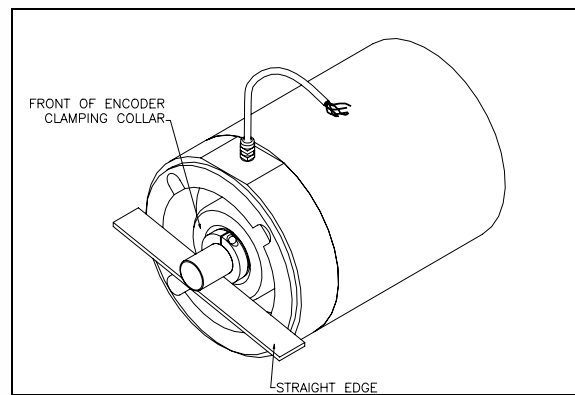

STEP 4

This step is for housing cover option A only.

Replace $\frac{1}{2} \times 13 \times \frac{3}{4}$ " bolts and washers through cover into tapped holes in C-face housing.

If you have questions regarding this Technical Bulletin, please call Technical Support at (800) 366-5412 or email techsupport@encoder.com.

TB-505.doc, Rev E, 05/02/02